

RMC-8356

User Manual

Worldwide Technical Support and Product Information

ni.com

Worldwide Offices

Visit ni.com/niglobal to access the branch office Web sites, which provide up-to-date contact information, support phone numbers, email addresses, and current events.

National Instruments Corporate Headquarters

11500 North Mopac Expressway Austin, Texas 78759-3504 USA Tel: 512 683 0100

For further support information, refer to the *NI Services* appendix. To comment on National Instruments documentation, refer to the National Instruments Web site at ni.com/info and enter the Info Code `feedback`.

Legal Information

Limited Warranty

This document is provided 'as is' and is subject to being changed, without notice, in future editions. For the latest version, refer to ni.com/manuals. NI reviews this document carefully for technical accuracy; however, NI MAKES NO EXPRESS OR IMPLIED WARRANTIES AS TO THE ACCURACY OF THE INFORMATION CONTAINED HEREIN AND SHALL NOT BE LIABLE FOR ANY ERRORS.

NI warrants that its hardware products will be free of defects in materials and workmanship that cause the product to fail to substantially conform to the applicable NI published specifications for one (1) year from the date of invoice.

For a period of ninety (90) days from the date of invoice, NI warrants that (i) its software products will perform substantially in accordance with the applicable documentation provided with the software and (ii) the software media will be free from defects in materials and workmanship.

If NI receives notice of a defect or non-conformance during the applicable warranty period, NI will, in its discretion: (i) repair or replace the affected product, or (ii) refund the fees paid for the affected product. Repaired or replaced Hardware will be warranted for the remainder of the original warranty period or ninety (90) days, whichever is longer. If NI elects to repair or replace the product, NI may use new or refurbished parts or products that are equivalent to new in performance and reliability and are at least functionally equivalent to the original part or product.

You must obtain an RMA number from NI before returning any product to NI. NI reserves the right to charge a fee for examining and testing Hardware not covered by the Limited Warranty.

This Limited Warranty does not apply if the defect of the product resulted from improper or inadequate maintenance, installation, repair, or calibration (performed by a party other than NI); unauthorized modification; improper environment; use of an improper hardware or software key; improper use or operation outside of the specification for the product; improper voltages; accident, abuse, or neglect; or a hazard such as lightning, flood, or other act of nature.

THE REMEDIES SET FORTH ABOVE ARE EXCLUSIVE AND THE CUSTOMER'S SOLE REMEDIES, AND SHALL APPLY EVEN IF SUCH REMEDIES FAIL OF THEIR ESSENTIAL PURPOSE.

EXCEPT AS EXPRESSLY SET FORTH HEREIN, PRODUCTS ARE PROVIDED "AS IS" WITHOUT WARRANTY OF ANY KIND AND NI DISCLAIMS ALL WARRANTIES, EXPRESSED OR IMPLIED, WITH RESPECT TO THE PRODUCTS, INCLUDING ANY IMPLIED WARRANTIES OF MERCHANTABILITY, FITNESS FOR A PARTICULAR PURPOSE, TITLE OR NON-INFRINGEMENT, AND ANY WARRANTIES THAT MAY ARISE FROM USAGE OF TRADE OR COURSE OF DEALING. NI DOES NOT WARRANT, GUARANTEE, OR MAKE ANY REPRESENTATIONS REGARDING THE USE OF OR THE RESULTS OF THE USE OF THE PRODUCTS IN TERMS OF CORRECTNESS, ACCURACY, RELIABILITY, OR OTHERWISE. NI DOES NOT WARRANT THAT THE OPERATION OF THE PRODUCTS WILL BE UNINTERRUPTED OR ERROR FREE.

In the event that you and NI have a separate signed written agreement with warranty terms covering the products, then the warranty terms in the separate agreement shall control.

Copyright

Under the copyright laws, this publication may not be reproduced or transmitted in any form, electronic or mechanical, including photocopying, recording, storing in an information retrieval system, or translating, in whole or in part, without the prior written consent of National Instruments Corporation.

National Instruments respects the intellectual property of others, and we ask our users to do the same. NI software is protected by copyright and other intellectual property laws. Where NI software may be used to reproduce software or other materials belonging to others, you may use NI software only to reproduce materials that you may reproduce in accordance with the terms of any applicable license or other legal restriction.

End-User License Agreements and Third-Party Legal Notices

You can find end-user license agreements (EULAs) and third-party legal notices in the following locations:

- Notices are located in the <National Instruments>_Legal Information and <National Instruments> directories.
- EULAs are located in the <National Instruments>\Shared\MDF\Legal\license directory.
- Review <National Instruments>_Legal Information.txt for information on including legal information in installers built with NI products.

U.S. Government Restricted Rights

If you are an agency, department, or other entity of the United States Government ("Government"), the use, duplication, reproduction, release, modification, disclosure or transfer of the technical data included in this manual is governed by the Restricted Rights provisions under Federal Acquisition Regulation 52.227-14 for civilian agencies and Defense Federal Acquisition Regulation Supplement Section 252.227-7014 and 252.227-7015 for military agencies.

Trademarks

Refer to the *NI Trademarks and Logo Guidelines* at ni.com/trademarks for more information on NI trademarks.

ARM, Keil, and μ Vision are trademarks or registered of ARM Ltd or its subsidiaries.

LEGO, the LEGO logo, WEDO, and MINDSTORMS are trademarks of the LEGO Group.

TETRIX by Pitsco is a trademark of Pitsco, Inc.

FIELDBUS FOUNDATION™ and FOUNDATION™ are trademarks of the Fieldbus Foundation.

EtherCAT® is a registered trademark of and licensed by Beckhoff Automation GmbH.

CANopen® is a registered Community Trademark of CAN in Automation e.V.

DeviceNet™ and EtherNet/IP™ are trademarks of ODVA.

Go!, SensorDAQ, and Vernier are registered trademarks of Vernier Software & Technology. Vernier Software & Technology and vernier.com are trademarks or trade dress.

Xilinx is the registered trademark of Xilinx, Inc.

Taptite and Trilobular are registered trademarks of Research Engineering & Manufacturing Inc.

FireWire® is the registered trademark of Apple Inc.

Linux® is the registered trademark of Linus Torvalds in the U.S. and other countries.

Handle Graphics®, MATLAB®, Simulink®, Stateflow®, and xPC TargetBox® are registered trademarks, and Simulink Coder™, TargetBox™, and Target Language Compiler™ are trademarks of The MathWorks, Inc.

Tektronix®, Tek, and Tektronix, Enabling Technology are registered trademarks of Tektronix, Inc.

The Bluetooth® word mark is a registered trademark owned by the Bluetooth SIG, Inc.

The ExpressCard™ word mark and logos are owned by PCMCIA and any use of such marks by National Instruments is under license.

The mark LabWindows is used under a license from Microsoft Corporation. Windows is a registered trademark of Microsoft Corporation in the United States and other countries.

Other product and company names mentioned herein are trademarks or trade names of their respective companies.

Members of the National Instruments Alliance Partner Program are business entities independent from NI and have no agency, partnership, or joint-venture relationship with NI.

Patents

For patents covering NI products/technology, refer to the appropriate location: **Help»Patents** in your software, the `patents.txt` file on your media, or the *National Instruments Patent Notice* at ni.com/patents.

Export Compliance Information

Refer to the *Export Compliance Information* at ni.com/legal/export-compliance for the NI global trade compliance policy and how to obtain relevant HTS codes, ECCNs, and other import/export data.

WARNING REGARDING USE OF NATIONAL INSTRUMENTS PRODUCTS

YOU ARE ULTIMATELY RESPONSIBLE FOR VERIFYING AND VALIDATING THE SUITABILITY AND RELIABILITY OF THE PRODUCTS WHENEVER THE PRODUCTS ARE INCORPORATED IN YOUR SYSTEM OR APPLICATION, INCLUDING THE APPROPRIATE DESIGN, PROCESS, AND SAFETY LEVEL OF SUCH SYSTEM OR APPLICATION.

PRODUCTS ARE NOT DESIGNED, MANUFACTURED, OR TESTED FOR USE IN LIFE OR SAFETY CRITICAL SYSTEMS, HAZARDOUS ENVIRONMENTS OR ANY OTHER ENVIRONMENTS REQUIRING FAIL-SAFE PERFORMANCE, INCLUDING IN THE OPERATION OF NUCLEAR FACILITIES; AIRCRAFT NAVIGATION; AIR TRAFFIC CONTROL SYSTEMS; LIFE SAVING OR LIFE SUSTAINING SYSTEMS OR SUCH OTHER MEDICAL DEVICES; OR ANY OTHER APPLICATION IN WHICH THE FAILURE OF THE PRODUCT OR SERVICE COULD LEAD TO DEATH, PERSONAL INJURY, SEVERE PROPERTY DAMAGE OR ENVIRONMENTAL HARM (COLLECTIVELY, "HIGH-RISK USES"). FURTHER, PRUDENT STEPS MUST BE TAKEN TO PROTECT AGAINST FAILURES, INCLUDING PROVIDING BACK-UP AND SHUT-DOWN MECHANISMS. NI EXPRESSLY DISCLAIMS ANY EXPRESS OR IMPLIED WARRANTY OF FITNESS OF THE PRODUCTS OR SERVICES FOR HIGH-RISK USES.

Compliance

Electromagnetic Compatibility Guidelines

This product was tested and complies with the regulatory requirements and limits for electromagnetic compatibility (EMC) stated in the product specifications. These requirements and limits provide reasonable protection against harmful interference when the product is operated in the intended operational electromagnetic environment.

This product is intended for use in locations other than residential locations. However, harmful interference may occur in some installations, when the product is connected to a peripheral device or test object, or if the product is used in residential areas. To minimize interference with radio and television reception and prevent unacceptable performance degradation, install and use this product in strict accordance with the instructions in the product documentation.

If this hardware does cause interference with licensed radio communications services or other nearby electronics, which can be determined by turning the hardware off and on, you are encouraged to try to correct the interference by one or more of the following measures:

- Reorient the antenna of the receiver (the device suffering interference).
- Relocate the transmitter (the device generating interference) with respect to the receiver.
- Plug the transmitter into a different outlet so that the transmitter and the receiver are on different branch circuits.

Furthermore, any modifications to the product not expressly approved by National Instruments could void your authority to operate it under your local regulatory rules.



Caution To ensure the specified EMC performance, operate this product only with shielded cables and accessories. Note that the input AC power cable may be unshielded.

Contents

Chapter 1

Getting Started

Unpacking.....	1-1
What You Need to Get Started.....	1-1
RMC-8356 Overview.....	1-2
Key Features.....	1-2
Mainboard Features.....	1-2
CPU.....	1-2
Chipset.....	1-2
Memory.....	1-2
Slots.....	1-3
Video.....	1-3
HDD.....	1-3
Onboard LAN.....	1-3
Onboard I/O.....	1-3
Power Supply.....	1-3
Fan.....	1-3
Power Management Features.....	1-3
Front Panel LEDs.....	1-4
System Management.....	1-4
RMC-8356 Description.....	1-4
Upgrade/Optional Equipment.....	1-6
Memory Upgrades.....	1-6
National Instruments Software.....	1-6

Chapter 2

Installation and BIOS Setup

Safety Information.....	2-1
Chassis Cooling Considerations.....	2-2
Providing Adequate Clearance.....	2-2
Installation.....	2-2
Connecting Safety Ground.....	2-3
Connecting to Power Source.....	2-3
BIOS Setup.....	2-3
Starting the Setup Utility.....	2-3
Main Setup.....	2-4
System Date/System Time.....	2-4
BIOS Version.....	2-4
Build Date.....	2-4
Memory Information.....	2-4
Total Memory.....	2-4
Memory Speed.....	2-4

Advanced Setup Configurations	2-4
Boot Feature.....	2-5
Power Configuration.....	2-5
CPU Configuration	2-6
CPU Thermal Configuration.....	2-9
Chipset Configuration.....	2-9
System Agent (SA) Configuration.....	2-9
Graphics Configuration.....	2-10
DMI/OPI Configuration.....	2-10
PEG Port Configuration.....	2-11
Memory Configuration	2-11
GT - Power Management Control	2-12
PCH-IO Configuration.....	2-13
PCI Express Configuration	2-13
PCH SLOT4 PCI-E 3.0 X4 (IN X8).....	2-13
PCH SLOT7 PCI-E 3.0 X4 (IN X8).....	2-13
SATA Configuration.....	2-14
PCIe/PCI/PnP Configuration	2-15
Super IO Configuration	2-17
PCH-FW Configuration	2-18
AMT Configuration	2-18
Serial Port Console Redirection.....	2-19
SOL/COM2 Console Redirection Settings	2-21
COM2 Legacy OS Redirection Resolution	2-22
EMS Console Redirection Settings.....	2-22
ACPI Settings	2-23
Trusted Computing Configuration.....	2-24
Security Device Support	2-24
TPM State	2-24
Pending TPM operation.....	2-24
Device Select	2-24
TXT Support	2-24
iSCSi Configuration.....	2-24
iSCSI Initiator Name	2-24
Intel I210 Gigabit Network Connection - 00:25:90:5D:39:AF	2-25
NIC Configuration	2-25
Intel Ethernet Connection (H) I219-LM 00:25:90:5D:39:AE	2-26
NIC Configuration	2-26
Event Logs	2-27
Change SMBIOS Event Log Settings.....	2-27
View SMBIOS Event Log	2-28

IPMI.....	2-28
System Event Log.....	2-28
BMC Network Configuration.....	2-28
BMC Network Configuration.....	2-28
IPMI LAN Selection.....	2-28
IPMI Network Link Status	2-29
Update IPMI LAN Configuration.....	2-29
Configuration Address Source.....	2-29
Current Configuration Address Source	2-29
Station IP Address	2-29
Subnet Mask	2-29
Station MAC Address.....	2-29
Gateway IP Address	2-29
IPMI Function Support.....	2-29
Security.....	2-30
Secure Boot Menu	2-30
Boot	2-32
Save & Exit.....	2-33
Default Options.....	2-33
BIOS Error Beep Codes	2-34
OS Reinstallation and Recovery.....	2-34
Cleaning.....	2-35
Exterior Cleaning.....	2-35
Rack Mounting	2-36
Installing the Rails	2-36
Identifying the Rails	2-36
Installing the Chassis Rails.....	2-36
Installing the Rack Rails.....	2-37
Installing the Server into a Rack.....	2-37
Installing the Server into a Telco Rack	2-38

Chapter 3

I/O Information

Rear Panel Connectors.....	3-1
Serial.....	3-1
SATA.....	3-1
Rear I/O	3-1
LAN.....	3-1
Universal Serial Bus (USB).....	3-2
VGA/DVI Port.....	3-3
DP (DisplayPort)	3-4
MXI-Express Connectors	3-4

Chapter 4

Common Configuration Questions

General Questions.....	4-1
Boot Options.....	4-2
Chassis Configuration.....	4-2
Upgrade Information.....	4-3

Chapter 5

Troubleshooting

Appendix A

Specifications

Appendix B

Hardware Configuration

Appendix C

Intel SATA RAID Utility for Intel C236

Appendix D

NI Services

Glossary

Index

Getting Started

This chapter describes the key features of the RMC-8356 and lists the kit contents and optional equipment you can order from National Instruments.

Unpacking

Carefully inspect the shipping container and the RMC-8356 for damage. Check for visible damage to the metal work. Check to make sure all hardware and switches are undamaged. If damage appears to have been caused during shipment, file a claim with the carrier. Retain the packing material for possible inspection and/or reshipment.

What You Need to Get Started

The RMC-8356 kit contains the following items:

- RMC-8356 rack mount controller
- RMC-8356 User Manual*
- Windows recovery USB
- Rack mount kit
- AC power cable (refer to Table 1-1 for a list of AC power cables)
- DisplayPort to VGA adapter



Note Onboard VGA is disabled by default. Use the included DisplayPort to VGA adapter to use a VGA monitor.

Table 1-1. AC Power Cables

Power Cable	Reference Standards
Standard 120 V (USA)	ANSI C73.11/NEMA 5-15-P/IEC83
Switzerland 220 V	SEV
Australia 240 V	AS C112
Universal Euro 230 V	CEE (7), II, IV, VII IEC83
North America 240 V	ANSI C73.20/NEMA 5-15-P/IEC83
United Kingdom 230 V	BS 1363/IEC83
Japan 100 V	ANSI C73.11/NEMA 5-15-P/IEC83

The unit comes with the standard 120 V (USA) cable. If you have the incorrect AC power cable, contact National Instruments.

RMC-8356 Overview

The RMC-8356 is a 1U PC-based controller for remote control of PXI chassis. The controller provides leading-edge processing power with Intel Xeon E3-1275-V5 processors, high disk bandwidth with RAID support, high I/O bandwidth with a PCI Express 3.0 x16, dedicated Intel Graphics w/ DP, and up to 64 GB of UDIMM Non-ECC memory.

Key Features

The RMC-8356 offers the performance of a high-end PC in a compact 1U rack-mountable form factor for controlling a PXI or PXI Express system using a National Instruments remote controller.

Mainboard Features

CPU

- Intel Xeon E3-1275-V5 3.6 GHZ, 80 W

Chipset

- Intel C236 chipset

Memory

- 16 GB UDIMM Non-ECC DDR4 memory standard (1 ×16 GB)
- Maximum memory supported: 64 GB Unregistered Non-ECC DDR4-2133Mhz in 4 DIMM sockets.

Slots

- 1 x PCI Express 3.0 x16 slot

Video

- Aspeed AST2400 BMC (max resolution 1280 × 1024), (disabled by default)
- Intel HD P530 Graphics, 2 × Display Port, 1 × DVI

HDD

- 1 x 500 GB SATA3 hard drive JBOD

Onboard LAN

- 1 x Intel PHY i219LM Gigabit Ethernet controller
- 1 x Intel I210-AT

Onboard I/O

- 1 x Front Serial port
- 1 x VGA port (disabled by default)
- 2 x Display Port
- 1 x DVI
- 2 x USB 2.0 ports (rear)
- 2 x USB 3.0 ports (rear)
- 2 x USB 3.0 ports (front)
- 2 x RJ-45 ports

Power Supply

- 350 W AC power supply w/ PFC

Fan

- Internal 4 x 4cm Fans

Power Management Features

- ACPI/ACPM power management
- Main switch override mechanism
- Wake-On-LAN (WOL) header
- Wake up on keyboard/mouse from Soft-Off
- Power-on mode from AC power recovery

Front Panel LEDs

- Power indicator
- Power shuttle indicators
- LAN status indicators
- HDD indicator
- System temp (overheat) and fan (fail) warning indicator

System Management

- Monitoring for CPU and chassis environment
- CPU thermal trip support
- +5 V standby alert LED
- Fan speed control

RMC-8356 Description

Figure 1-1 shows the key features of the RMC-8356 front panel. For detailed information about the RMC-8356 rear panel, refer to Chapter 3, *I/O Information*.

Figure 1-1. Front View of the RMC-8356

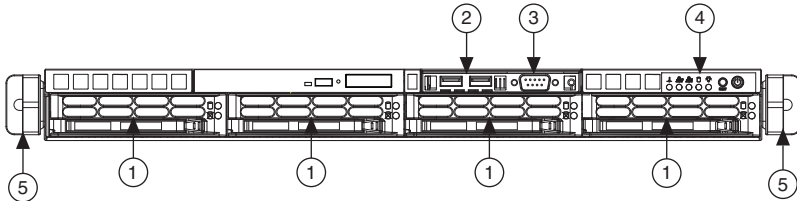

1	SATA HDD	4	Control Panel
2	USB Ports	5	Rack Ear Brackets
3	COM Port		

The front of the chassis includes the following features:

- **SATA HDD**—Hot-swap 3.5" SATA hard disk drive.
- **USB Ports**—Two front-access USB 3.0 ports.
- **COM Port**—Front-access COM (Serial) port.
- **Control Panel**—Front control panel with LEDs and buttons.
- **Rack Ear Brackets**—Attaches server chassis to the rack.

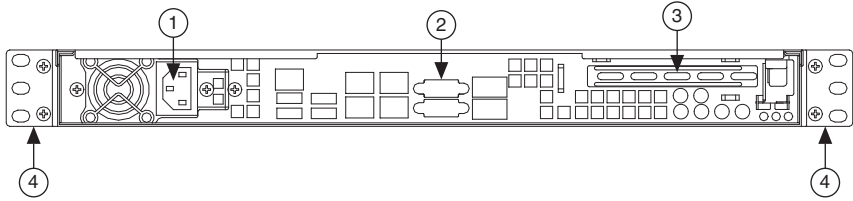
Figure 1-2. Rear View of the RMC-8356

1	Power Supply	3	Expansion Card Slot
2	I/O Back Panel	4	Rack Ear Brackets

The rear of the chassis includes the following features:

- **Power Supply**—350 W Platinum Level Power Supply.
- **I/O Back Panel**—Rear I/O ports.
- **Expansion Card Slot**—Slot for one expansion card (requires pre-installed riser card).
- **Rack Ear Brackets**—Attaches server chassis to the rack.

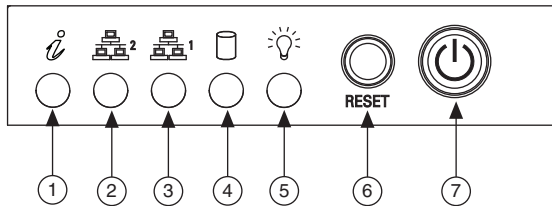
Figure 1-3. Control Panel Features

1	Overheat/Fan Fail LED	5	Power LED
2	NIC2 LED	6	Reset Button
3	NIC1 LED	7	Power Button
4	HDD LED		

The control panel includes the following LEDs:

- **Overheat/Fan Fail LED**—Flash indicates a fan failure. Solid indicates overheat condition.
- **NIC2 LED**—Flash when there is activity on LAN port 2.
- **NIC1 LED**—Flash when there is activity on LAN port 1.
- **HDD LED**—Flash when there is hard drive activity.
- **Power LED**—Solid when system is operating.
- **Reset Button**—Reboots the system.
- **Power Button**—Removes the main power but maintains standby power. To perform many maintenance tasks, you *must* also unplug system before servicing.

Upgrade/Optional Equipment

Memory Upgrades

National Instruments has tested and verified that the DDR-4 UDIMMs and HDDs we offer work with the RMC-8356. We recommend you purchase your DDR-4 UDIMM and HDD modules from National Instruments. Other off-the-shelf DDR-4 UDIMM and HDD modules are not guaranteed to work properly.

National Instruments Software

National Instruments hardware and software work together to help you make the most of your PXI Express system. The LabVIEW, Measurement Studio, and LabWindows™/CVI™ application development environments combine with leading hardware drivers such as NI-DAQmx to provide exceptional control of NI hardware. Instrument drivers are available at ni.com/idnet to simplify communication with instruments over a variety of buses.

LabVIEW is a powerful and easy-to-use graphical programming environment you can use to acquire data from thousands of different instruments including USB, IEEE 488.2, VXI, serial, PLCs, and plug-in boards. LabVIEW helps you convert acquired data into meaningful results using powerful data analysis routines. Add-on tools provide additional specialized functionality. For more information, visit ni.com/labview and ni.com/toolkits.

If you prefer to use Microsoft's Visual Basic, Visual C++, and Visual Studio .NET for the core of your application, Measurement Studio adds tools for measurement and automation to each language. For more information, visit ni.com/mstudio.

LabWindows/CVI is an interactive ANSI C programming environment designed for building virtual instrument applications. LabWindows/CVI includes a drag-and-drop editor for building user interfaces, a complete ANSI C environment for building your test program logic, and a collection of automated code generation tools, as well as utilities for building automated test systems, monitoring applications, or laboratory experiments. For more information, visit ni.com/lwcvci.

NI-DAQmx provides an extensive library of functions you can call from your application development environment or interactive environment, such as NI Signal Express. These functions provide an intuitive API for National Instruments multifunction DAQ products. Features include analog input (A/D conversion), buffered data acquisition (high-speed A/D conversion), analog output (D/A conversion), waveform generation, digital I/O, counter/timer operations, SCXI signal conditioning, RTSI or PXI synchronization, self-calibration, messaging, and acquiring data to extended memory. For more information, visit ni.com/daq.

National Instruments modular instruments use specialized drivers suited to each product's specialization. Express VIs provide customized, interactive programming of instruments in a single interface, and soft front panels provide an interface for testing the functionality of each instrument with no programming required. NI switches, DMMs, high-speed DIO, high-speed

digitizers, and sources each have customized drivers for high-end modular instrumentation systems. RF applications leverage two drivers, NI-RFSG and NI-RFSA, and dynamic signal acquisition is available through NI-DAQmx. For more information, visit ni.com/modularinstruments.

You can expand the timing and triggering functionality of your PXI system with PXI timing and synchronization products. These products provide precision clock sources, custom routing of triggers for multichassis synchronization, clock sharing, and more, and are programmed with NI-Sync. For more information, visit ni.com/pxi.

NI-VISA is the National Instruments implementation of the VISA specification. VISA is a uniform API for communicating and controlling USB, Serial, GPIB, PXI, VXI, and various other types of instruments. This API aids in the creation of portable applications and instrument drivers. For information about writing your own PXI instrument driver with NI-VISA, refer to the *NI-VISA Help* and the `readme.txt` file in the NI-VISA directory. For more information, visit ni.com/visa.

Installation and BIOS Setup

This chapter describes how to install, configure, and use the RMC-8356. Read this chapter before connecting the RMC-8356 to a power source.

Safety Information



Caution Before undertaking any troubleshooting, maintenance, or exploratory procedure, carefully read the following caution notices.



Caution To prevent damage, you must employ industry-standard ESD prevention measures during installation, maintenance, and operation.



Caution Overloading the circuits may damage supply wiring. Do not exceed the ratings on the equipment nameplate when connecting equipment to the supply circuit.



Caution There is a danger of explosion if the onboard battery is installed upside down (which reverses its polarities). This battery must be replaced only with the same or an equivalent type recommended by the manufacturer (CR2032).

This equipment contains voltage hazardous to human life and safety, and is capable of inflicting personal injury.

- **Chassis Grounding**—The RMC-8356 requires a connection from the premise wire safety ground to the RMC-8356 chassis ground. The earth safety ground *must* be connected during use of this equipment to minimize shock hazards. Refer to the [Connecting Safety Ground](#) section for instructions on connecting safety ground.
- **Mechanical Loading**—To avoid a hazardous load condition, be sure the mechanical load is even when rack mounting the equipment.
- **Live Circuits**—Operating personnel and service personnel must *not* remove protective covers when operating or servicing the RMC-8356. Adjustments and service to internal components must be undertaken by qualified service technicians. During service of this product, the main connector to the premise wiring must be disconnected. Dangerous voltages may be present under certain conditions; use extreme caution.
- **Explosive Atmosphere**—Do *not* operate the chassis in conditions where flammable gases are present. Under such conditions, this equipment is unsafe and may ignite the gases or gas fumes.

- **Parts Replacement**—Service this equipment only with parts that are exact replacements, both electrically and mechanically. Contact National Instruments for replacement part information. Installation of parts with those that are not direct replacements may cause harm to personnel operating the chassis. Furthermore, damage or fire may occur if replacement parts are unsuitable.
- **Modification**—Do *not* modify any part of the RMC-8356 from its original condition. Unsuitable modifications may result in safety hazards.

Chassis Cooling Considerations

The RMC-8356 is designed to operate on a bench or in an instrument rack. Determine how you want to use the RMC-8356 and follow the appropriate installation instructions.



Caution If installed in a closed or multiunit rack assembly, the rack environment operating ambient temperature may be greater than room ambient temperature. Therefore, install the equipment in an environment compatible with the maximum ambient operating temperature (T_{ma}) specified in Appendix A, *Specifications*.

Providing Adequate Clearance

Apertures in the front and rear of the chassis facilitate power supply and motherboard cooling. Air enters through the front of the chassis and exits through the fans on the rear of the chassis. Place the RMC-8356 on a bench top or in an instrument rack so that the fans (air outlets) and the air inlet apertures in the front and rear of the chassis have adequate ventilation. Keep other equipment a minimum of 76.2 mm (3 in.) away from the air outlets on the rear of the chassis.

Installation

Follow these steps to connect devices to the RMC-8356:

1. Connect a keyboard and mouse to the appropriate connectors on the RMC-8356 rear panel.
2. Connect the DisplayPort or DVI monitor video cable to the corresponding DisplayPort or DVI connector on the rear panel.
3. Connect the USB and serial devices as necessary to the RMC-8356 front and rear panel ports.



Caution To minimize shock hazard, make sure the electrical power outlet you use to power the RMC-8356 has an appropriate earth safety ground. Refer to the *Connecting Safety Ground* section for more information.

4. Connect the AC power cable to the AC inlet on the rear panel and to an AC power outlet. For more information, refer to the *Connecting to Power Source* section.
5. Power on the RMC-8356.
6. Verify that the RMC-8356 boots. If it does not boot, refer to the *What if the RMC-8356 does not boot?* section of Chapter 5, *Troubleshooting*.

Connecting Safety Ground

The RMC-8356 is designed with a three-position NEMA 5-15 style plug for the U.S. that connects the ground line to the chassis ground. To minimize shock hazard, make sure the electrical power outlet you use to power the chassis has an appropriate earth safety ground.

Connecting to Power Source

Attach input power through the rear AC inlet using the appropriate AC power cable supplied.



Caution Overloading the circuits may damage supply wiring. Do not exceed the ratings on the equipment nameplate when connecting equipment to the supply circuit.



Caution To completely remove power, you *must* disconnect the AC power cable.

The power switch allows you to power on the chassis or place it in standby mode. Push the power switch to the On position (if not already on). Observe that all fans become operational and the power indicator is lit.

BIOS Setup

This section describes the AMIBIOS™ Setup utility for the RMC-8356 motherboard. The BIOS is stored on a chip and can be easily upgraded using a flash program.



Note Due to periodic changes to the BIOS, some settings may have been added or deleted and might not yet be recorded in this manual. Refer to ni.com/downloads for any changes to BIOS that may not be reflected in this manual.

Starting the Setup Utility

To enter the BIOS Setup Utility, hit the <Delete> key while the system is booting-up. (In most cases, the <Delete> key is used to invoke the BIOS setup screen. There are a few cases when other keys are used, such as <F1>, <F2>, etc.) Each main BIOS menu option is described in this manual.

The Main BIOS screen has two main frames. The left frame displays all the options that can be configured. Grayed-out options cannot be configured. The right frame displays the key legend. Above the key legend is an area reserved for a text message. When an option is selected in the left frame, it is highlighted in white. Often a text message will accompany it. (Note that BIOS has default text messages built in. We retain the option to include, omit, or change any of these text messages.)

Highlighting a submenu and pressing the <Enter> key will open the list of settings within that submenu.

The BIOS setup utility uses a key-based navigation system called hot keys. Most of these hot keys (<F1>, <F10>, <Enter>, <ESC>, <Arrow> keys, etc.) can be used at any time during the setup navigation process.

Main Setup

When you first enter the AMI BIOS setup utility, you will enter the Main setup screen. You can always return to the Main setup screen by selecting the Main tab on the top of the screen. The Main BIOS setup screen is shown below. The following Main menu items will be displayed:

System Date/System Time

Use this option to change the system date and time. Highlight *System Date* or *System Time* using the arrow keys. Enter new values using the keyboard. Press the <Tab> key or the arrow keys to move between fields. The date must be entered in Day MM/DD/YYYY format. The time is entered in HH:MM:SS format.



Note The time is in the 24-hour format. For example, 5:30 P.M. appears as 17:30:00. The date's default value is 01/01/2015 after RTC reset.

BIOS Version

This item displays the version of the BIOS ROM used in the system.

Build Date

This item displays the date when the version of the BIOS ROM used in the system was built.

Memory Information

Total Memory

This item displays the total size of memory available in the system.

Memory Speed

This item displays the memory speed.

Advanced Setup Configurations

Use the arrow keys to select Boot Setup and press <Enter> to access the submenu items.



Caution Take caution when changing the Advanced settings. An incorrect value, a very high DRAM frequency, or an incorrect DRAM timing setting may make the system unstable. When this occurs, revert to the default to the manufacture default settings.

Boot Feature

Quiet Boot

Use this feature to select the screen display between the POST messages and the OEM logo upon bootup. Select Disabled to display the POST messages. Select Enabled to display the OEM logo instead of the normal POST messages. The options are **Enabled** and **Disabled**.

AddOn ROM Display Mode

Use this feature to set the display mode for the Option ROM. Select Keep Current to display the current AddOn ROM setting. Select Force BIOS to use the Option ROM display set by the system BIOS. The options are **Force BIOS** and **Keep Current**.

Bootup NumLock State

Use this feature to set the Power-on state for the <Numlock> key. The options are **Off** and **On**.

Wait For “F1” If Error

Use this feature to force the system to wait until the “F1” key is pressed if an error occurs. The options are **Disabled** and **Enabled**.

INT19 (Interrupt 19) Trap Response

Interrupt 19 is the software interrupt that handles the boot disk function. When this item is set to Immediate, the ROM BIOS of the host adapters will capture Interrupt 19 at bootup immediately and allow the drives that are attached to these host adapters to function as bootable disks. If this item is set to Postponed, the ROM BIOS of the host adapters will not capture Interrupt 19 immediately and allow the drives attached to these adapters to function as bootable devices at bootup. The options are **Immediate** and **Postponed**.

Re-try Boot

If this item is enabled, the BIOS will automatically reboot the system from a specified bootdevice after its initial boot failure. The options are **Disabled**, **Legacy Boot**, and **EFI Boot**.

Power Configuration

Watch Dog Function

If enabled, the Watch Dog Timer will allow the system to reset or generate NMI based on jumper settings when it is expired for more than 5 minutes. The options are **Enabled** and **Disabled**.

Power Button Function

This feature controls how the system shuts down when the power button is pressed. Select **4_Seconds_Override** for the user to power off the system after pressing and holding the power button for 4 seconds or longer. Select **Instant Off** to instantly power off the system as soon as the user presses the power button. The options are **4 Seconds Override** and **Instant Off**.

Restore on AC Power Loss

Use this feature to set the power state after a power outage. Select Stay-Off for the system power to remain off after a power loss. Select Power-On for the system power to be turned on after a power loss. Select Last State to allow the system to resume its last power state before a power loss. The options are **Power-On**, **Stay-Off** and **Last State**.

CPU Configuration

The following CPU information will display:

- CPU Signature
- Microcode Patch
- Max CPU Speed
- Min CPU Speed
- CPU Speed
- Processor Cores
- Hyper Threading Technology
- Intel VT-x Technology
- Intel SMX Technology
- 64-bit
- EIST Technology
- CPU C3 State
- CPU C6 State
- CPU C7 State
- L1 Data Cache
- L1 Code Cache
- L2 Cache
- L3 Cache
- L4 Cache

Hyper-threading (Available when supported by the CPU)

Select Enabled to support Intel Hyper-threading Technology to enhance CPU performance. The options are **Enabled** and **Disabled**.

Active Processor Cores

This feature determines how many CPU cores will be activated for each CPU. When all is selected, all cores in the CPU will be activated. (Refer to Intel's website for more information.) The options are **All** and **1**, **2**, and **3**.

Intel® Virtualization Technology

Select **Enabled** to use Intel Virtualization Technology so that I/O device assignments will be reported directly to the VMM (Virtual Memory Management) through the DMAR ACPI Tables. This feature offers fully-protected I/O resource-sharing across the Intel platforms, providing the user with greater reliability, security and availability in networking and data-sharing. The settings are **Enabled** and **Disabled**.

Hardware Prefetcher (Available when supported by the CPU)

If set to **Enabled**, the hardware prefetcher will prefetch streams of data and instructions from the main memory to the L2 cache to improve CPU performance. The options are **Disabled** and **Enabled**.

Adjacent Cache Line Prefetch (Available when supported by the CPU)

The CPU prefetches the cache line for 64 bytes if this feature is set to **Disabled**. The CPU prefetches both cache lines for 128 bytes as comprised if this feature is set to **Enabled**.

CPU AES

Select **Enabled** to enable Intel CPU Advanced Encryption Standard (AES) Instructions for CPU to enhance data integrity. The options are **Enabled** and **Disabled**.

Boot Performance Mode

This feature allows the user to select the performance state that the BIOS will set before the operating system handoff. The options are **Power Saving**, **Max Non-Turbo Performance** and **Turbo Performance**.

HardWare P-States (HWP)

Use this feature to enable or disable hardware P-States support. The options are **Disabled** and **Enabled**.

Intel® SpeedStep™

Intel SpeedStep Technology allows the system to automatically adjust processor voltage and core frequency to reduce power consumption and heat dissipation. The options are **Disabled** and **Enabled**.

Turbo Mode

Select **Enabled** for processor cores to run faster than the frequency specified by the manufacturer. The options are **Disabled** and **Enabled**.

Package Power Limit MSR Lock

Select **Enabled** to lock the package power limit for the model specific registers. The options are **Disabled** and **Enabled**.

Power Limit 1 Override

Select Enabled to support average power limit (PL1) override. The default setting is **Disabled**.

Power Limit 2 Override

Select Enabled to support rapid power limit (PL2) override. The default setting is **Enabled**.

Power Limit 2

Use this item to configure the value for Power Limit 2. The value is in milliwatts and the step size is 125 mW. Use the number keys on your keyboard to enter the value. Enter **0** to use the manufacture default setting. If the value is 0, the BIOS will set PL2 as 1.25* TDP.

Core Ratio Limit Override

This increases (multiplies) 1 clock speed in the CPU core in relation to the bus speed when one CPU core is active. Press + or - on your keyboard to change the value. Enter 0 to use the manufacture default setting.

Core Ratio Limit Override

This increases (multiplies) 2 clock speeds in the CPU core in relation to the bus speed when two CPU cores are active. Press + or - on your keyboard to change the value. Enter 0 to use the manufacture default setting.

Core Ratio Limit Override

This increases (multiplies) 3 clock speeds in the CPU core in relation to the bus speed when three CPU cores are active. Press + or - on your keyboard to change the value. Enter 0 to use the manufacture default setting.

Core Ratio Limit Override

This increases (multiplies) 4 clock speeds in the CPU core in relation to the bus speed when three CPU cores are active. Press + or - on your keyboard to change the value. Enter 0 to use the manufacture default setting.

CPU C-States

Use this feature to enable the C-State of the CPU. The options are **Disabled** and **Enabled**.

Enhanced C-States

Use this feature to enable the enhanced C-State of the CPU. The options are **Disabled** and **Enabled**.

C-State Auto Demotion

Use this feature to prevent unnecessary excursions into the C-states to improve latency. The options are **Disabled**, **C1**, **C3**, and **C1 and C3**.

C-State Un-Demotion

This feature allows the user to enable or disable the un-demotion of C-State. The options are **Disabled**, **C1**, **C3**, and **C1 and C3**

Package C-State Demotion

Use this feature to enable or disable the Package C-State demotion. The options are **Disabled** and **Enabled**.

Package C-State Un-Demotion

Use this feature to enable or disable the Package C-State un-demotion. The options are **Disabled** and **Enabled**.

C-State Pre-Wake

This feature allows the user to enable or disable the C-State Pre-Wake. The options are **Disabled** and **Enabled**.

Package C-State Limit

Use this feature to set the Package C-State limit. The options are **C0/C1**, **C2**, **C3**, **C6**, **C7**, **C7s**, **C8**, and **AUTO**.

CPU Thermal Configuration

CPU DTS

Select Enabled for the ACPI thermal management to use the DTS SMM mechanism to obtain CPU temperature values. Select Disabled for EC to report the CPU temperature values. The options are **Disabled** and **Enabled**.

ACPI 3.0 T-States

Select Enabled to support CPU throttling by the operating system to reduce power consumption. The options are **Enabled** and **Disabled**.

Chipset Configuration



Caution Setting the wrong values in the following features may cause the system to malfunction.

System Agent (SA) Configuration

The following System Agent information will display:

- System Agent Bridge Name
- SA PCIe Code Version
- VT-d

VT-d

Select **Enabled** to enable Intel Virtualization Technology support for Direct I/O VT-d by reporting the I/O device assignments to VMM through the DMAR ACPI Tables. This feature offers fully-protected I/O resource-sharing across the Intel platforms, providing the user with greater reliability, security and availability in networking and data-sharing. The options are **Enabled** and **Disabled**.

Gaussian Mixture Model

This feature is to enable or disable the System Agent Gaussian Mixture Model device. The options are **Enabled** and **Disabled**.

Graphics Configuration

Primary Display

Use this feature to select the graphics device to be used as the primary display. The options are **Auto**, **IGFX**, **PEG**, and **PCIE**.

Primary PEG

This feature allows the user to select the primary PCI Express Graphics (PEG) slot. The default setting is **CPU SLOT6 PCI-E 3.0 X16**.

Primary PCIE (PCI-Express Graphics)

This feature allows the user to specify which graphics card to be used as the primary graphics card. The options are **Auto**, **PCH SLOT4 PCI-E 3.0 X4 (IN X8)**, **Onboard**, and **PCH SLOT7 PCI-E 3.0 X4 (INX8)**.

Internal Graphics

Select **Auto** to keep an internal graphics device installed on an expansion slot supported by the CPU to be automatically enabled. The options are **Auto**, **Disabled**, and **Enabled**.

DMI/OPI Configuration

The following DMI information will display:

- DMI

DMI VC1 Control

Use this feature to enable or disable DMI Virtual Channel 1. The options are **Enabled** and **Disabled**.

DMI VCm Control

Use this feature to enable or disable the DMI Virtual Channel map. The options are **Enabled** and **Disabled**.

DMI Link ASPM Control

Use this feature to set the ASPM (Active State Power Management) state on the SA (System Agent) side of the DMI Link. The options are **Disabled** and **L1**.

DMI Extended Sync Control

Use this feature to enable or disable the DMI extended synchronization. The options are **Disabled** and **Enabled**.

DMI De-Emphasis Control

Use this feature to configure the De-emphasis control on DMI. The options are **-6dB** and **-3.5dB**.

PEG Port Configuration

SLOT6 Max Link Speed

This feature allows the user to select PCI-E support for the device installed on SLOT6. The options are **Auto**, **Gen 1**, **Gen 2**, and **Gen 3**.

SLOT6 Max Payload Size

Use this feature to select the PEG0 maximum payload size. The options are **Auto**, **128 TLP**, and **256 TLP**.

SLOT6 Power Limit Value

Use this feature to set the upper limit on the power supplied by the PCIE slot. Press + or - on your keyboard to change this value. The default setting is **75**.

SLOT6 Power Limit Scale

Use this feature to select the scale used for the slot power limit value. The options are **1.0x**, **0.1x**, **0.01x**, and **0.001x**.

Program PCIe ASPM After OPROM

PCIe ASPM, the Active State Power Management for PCI-Express slots, is a power management protocol used to manage power consumption of serial-link devices installed on PCI-Exp slots during a prolonged off-peak time. If this item is set to Enabled, PCI-E ASPM will be programmed after OPROM. If this item is set to Disabled, the PCI-E ASPM will be programmed before OPROM. The options are **Disabled** and **Enabled**.

Memory Configuration

The following memory information will display:

- Memory RC Version
- Memory Frequency
- Total Memory

- VDD
- DIMMA1
- DIMMA2
- DIMMB1
- DIMMB2
- Memory Timings (tCL-tRCD-tRP-tRAS)

Maximum Memory Frequency

Use this feature to set the maximum memory frequency for onboard memory modules. The options are **Auto**, **1067**, **1200**, **1333**, **1400**, **1600**, **1800**, **1867**, **2000**, **2133**, **2200**, **2400**, **2600**, **2667**, **2800**, **2933**, **3000**, and **3200**.

Max TOLUD

This feature sets the maximum TOLUD value, which specifies the Top of Low Usable DRAM memory space to be used by internal graphics devices, GTT Stolen Memory, and TSEG, respectively, if these devices are enabled. The options are **Dynamic**, **1 GB**, **1.25 GB**, **1.5 GB**, **1.75 GB**, **2 GB**, **2.25 GB**, **2.5 GB**, **2.75 GB**, **3 GB**, **3.25 GB**, and **3.5 GB**.

Energy Performance Gain

Use this feature to enable or disable the energy performance gain. The options are **Disabled** and **Enabled**.

Memory Scrambler

Select Enabled to enable memory scrambler support. The options are **Disabled** and **Enabled**.

Fast Boot

Use this feature to enable or disable fast path through the memory reference code. The options are **Enabled** and **Disabled**.

REFRESH_2X_MODE

Use this feature to select the refresh mode. The options are **Disabled**, **1-Enabled for WARM** or **HOT**, and **2-Enabled HOT only**.

GT - Power Management Control

The following GT - Power Management Control information will display:

- GT Info

RC6 (Render Standby)

Select Enabled to enable render standby support. The options are **Disabled** and **Enabled**.

PCH-IO Configuration

The following PCH-IO information will display:

- Intel PCH RC Version
- Intel PCH SKU Name
- Intel PCH Rev ID

PCI Express Configuration

DMI Link ASPM Control

Use this feature to set the ASPM (Active State Power Management) state on the SA (System Agent) side of the DMI Link. The options are **Disabled** and **Enabled**.

Peer Memory Write Enable

Use this feature to enable or disable peer memory write. The options are **Disabled** or **Enabled**.

PCH SLOT4 PCI-E 3.0 X4 (IN X8)

SLOT4 ASPM Support

Use this item to set the Active State Power Management (ASPM) level for a PCI-E device. Select Auto for the system BIOS to automatically set the ASPM level based on the system configuration. Select Disabled to disable ASPM support. The options are **Disabled**, **L0s**, **L1**, **L0s & L1**, and **Auto**.

SLOT4 L1 Substates

Use this feature to configure the PCI Express L1 Substates. The options are **Disabled**, **L1.1**, **L1.2**, and **L1.1 & L1.2**

SLOT4 PCIe Speed

Use this feature to select the PCI Express port speed. The options are **Auto**, **Gen1**, **Gen2**, and **Gen3**.

SLOT4 Detect Non-Compliance Device

Select Enabled for the AMI BIOS to automatically detect a PCI-E device that is not compliant with the PCI-E standards. The options are **Disabled** and **Enabled**.

PCH SLOT7 PCI-E 3.0 X4 (IN X8)

SLOT7 ASPM Support

Use this item to set the Active State Power Management (ASPM) level for a PCI-E device. Select Auto for the system BIOS to automatically set the ASPM level based on the system configuration. Select Disabled to disable ASPM support. The options are **Disabled**, **L0s**, **L1**, **L0s & L1**, and **Auto**.

SLOT7 L1 Substates

Use this feature to set the PCI Express L1 Substates. The options are **Disabled**, **L1.1**, **L1.2**, and **L1.1 & L1.2**.

SLOT7 PCIe Speed

Use this feature to select the PCI Express port speed. The options are **Auto**, **Gen1**, **Gen2**, and **Gen3**.

SLOT7 Detect Non-Compliance Device

Select Enabled for the AMI BIOS to automatically detect a PCI-E device that is not compliant with the PCI-E standards. The options are **Disabled** and **Enabled**.

Port 61h bit-4 Emulation

Select Enabled to enable the emulation of Port 61h bit-4 toggling in SMM (System Management Mode). The options are **Disabled** and **Enabled**.

PCIe PLL SSC

Enable this feature to reduce EMI interference by down spreading clock 0.5%. Disable this feature to centralize the clock without spreading. The options are **Disabled** and **Enabled**.

SATA Configuration

When this submenu is selected, the AMI BIOS automatically detects the presence of the SATA devices that are supported by the Intel PCH chip and displays the following items:

SATA Controller(s)

This item enables or disables the onboard SATA controller supported by the Intel PCH chip. The options are **Enabled** and **Disabled**.

SATA Mode Selection

Use this item to select the mode for the installed SATA drives. The options are **AHCI** and **RAID**.

SATA Frozen

Use this item to enable the HDD Security Frozen Mode. The options are **Enabled** and **Disabled**.



Note If the item above **SATA Mode Selection** is set to **RAID**, the following items will display:

SATA RAID Option ROM/UEFI Driver

Select UEFI to load the EFI driver for system boot. Select Legacy to load a legacy driver for system boot. The options are **Legacy ROM** and **UEFI Driver**.

SATA Port 0 ~ Port 3

This item displays the information detected on the installed SATA drive on the particular SATA port.

- Model number of drive and capacity
- Software Preserve Support

Port 0 ~ Port 3 Spin Up Device

On an edge detect from 0 to 1, set this item to allow the PCH to initialize the device. The options are **Enabled** and **Disabled**.

Port 0 ~ Port 3 SATA Device Type

Use this item to specify if the SATA port specified by the user should be connected to a Solid State drive or a Hard Disk Drive. The options are **Hard Disk Drive** and **Solid State Drive**.

PCIe/PCI/PnP Configuration

The following information will display:

- PCI Bus Driver Version
- PCI Devices Common Settings:

PCI PERR/SERR Support

Select Enabled to allow a PCI device to generate a PERR/SERR number for a PCI Bus Signal Error Event. The options are **Enabled** and **Disabled**.

Above 4G Decoding (Available if the system supports 64-bit PCI decoding)

Select Enabled to decode a PCI device that supports 64-bit in the space above 4G Address. The options are **Enabled** and **Disabled**.

PCH SLOT4 PCI-E 3.0 X4 (IN X8)

Use this feature to select which firmware type to be loaded for the add-on card in this slot.

The options are **Disabled**, **Legacy**, and **EFI**.

CPU SLOT6 PCI-E 3.0 X16

Use this feature to select which firmware type to be loaded for the add-on card in this slot.

The options are **Disabled**, **Legacy**, and **EFI**.

PCH SLOT 7 PCI-E 3.0 X4 (IN X8)

Use this feature to select which firmware type to be loaded for the add-on card in this slot.

The options are **Disabled**, **Legacy**, and **EFI**.

Onboard LAN Option ROM Type

Select Enabled to enable Option ROM support to boot the computer using a network device specified by the user. The options are **Legacy** and **EFI**.

Onboard LAN1 Option ROM

Use this option to select the type of device installed in LAN Port1 used for system boot. The default setting for LAN1 Option ROM is **PXE**.

Onboard LAN2 Option ROM

Use this option to select the type of device installed in LAN Port2 used for system boot. The default setting for LAN2 Option ROM is **Disabled**.

Onboard LAN3 Option ROM

Use this option to select the type of device installed in LAN Port3 used for system boot. The default setting for LAN3 Option ROM is **Disabled** (X11SSZ-TLN4F only).

Onboard LAN4 Option ROM

Use this option to select the type of device installed in LAN Port4 used for system boot. The default setting for LAN4 Option ROM is **Disabled** (X11SSZ-TLN4F only).

Onboard Video Option ROM

Use this feature to select which firmware type to be loaded for the onboard video controller.

The options are **Disabled**, **Legacy**, and **EFI**.

Network Stack

Select Enabled to enable PXE (Preboot Execution Environment) or UEFI (Unified Extensible Firmware Interface) for network stack support.

The options are **Enabled** and **Disabled**.

IPv4 PXE Support

Select Enabled to enable IPv4 PXE boot support. The options are **Enabled** and **Disabled**.

IPv6 PXE Support

Select Enabled to enable IPv6 PXE boot support. The options are **Enabled** and **Disabled**.

PXE boot wait time

Use this option to specify the wait time to press the ESC key to abort the PXE boot. Press + or - on your keyboard to change the value. The default setting is **0**.

Media detect count

Use this option to specify the number of times media will be checked. Press + or - on your keyboard to change the value. The default setting is **1**.

Super IO Configuration

The following Super IO information will display:

- AMI SIO Driver Version

Super IO Chip Logical Device(s) Configuration

Serial Port 1

Serial Port 1 Configuration

This submenu allows the user the configure settings of Serial Port 1.

Serial Port 1

Select Enabled to enable the selected onboard serial port. The options are **Enabled** and **Disabled**.

Logical Device Settings

This item displays the status of a serial part specified by the user.

Serial Port 1 Change Settings

This feature specifies the base I/O port address and the Interrupt Request address of a serial port specified by the user. Select Auto to allow the BIOS to automatically assign the base I/O and IRQ address.

The options for Serial Port 1 are **Use Automatic Settings**, (IO=3F8h; IRQ=4; DMA), (IO=3F8h; IRQ=3, 4, 5, 6, 7, 9, 10, 11, 12; DMA), (IO=2F8h; IRQ=3, 4, 5, 6, 7, 9, 10, 11, 12; DMA), (IO=3E8h; IRQ=3, 4, 5, 6, 7, 9, 10, 11, 12; DMA), and (IO=2E8h; IRQ=3, 4, 5, 6, 7, 9, 10, 11, 12; DMA).

Serial Port 2

Serial Port 2 Configuration

This submenu allows the user the configure settings of Serial Port 1.

Serial Port 2

Select Enabled to enable the selected onboard serial port. The options are **Enabled** and **Disabled**.

Logical Device Settings

This item displays the status of a serial part specified by the user.

Serial Port 2 Change Settings

This feature specifies the base I/O port address and the Interrupt Request address of a serial port specified by the user. Select Auto to allow the BIOS to automatically assign the base I/O and IRQ address.

The options for Serial Port 2 are **Use Automatic Settings**, (IO=2F8h; IRQ=3; DMA), (IO=3F8h; IRQ=3, 4, 5, 6, 7, 9, 10, 11, 12; DMA), (IO=2F8h; IRQ=3, 4, 5, 6, 7, 9, 10, 11, 12; DMA), (IO=3E8h; IRQ=3, 4, 5, 6, 7, 9, 10, 11, 12; DMA), and (IO=2E8h; IRQ=3, 4, 5, 6, 7, 9, 10, 11, 12; DMA).

Serial Port 2 Attribute (Available for Serial Port 2 only)

Select SOL to use COM Port 2 as a Serial_Over_LAN (SOL) port for console redirection. The options are **COM** and **SOL**.

PCH-FW Configuration

The following firmware information will display:

- ME FW Version
- ME Firmware Mode
- ME Firmware Type
- ME Firmware SKU

ME FW Image Re-Flash

Use this feature to update the Management Engine firmware. The options are **Enabled** and **Disabled**.

AMT Configuration

Intel AMT

Select Enabled to use Intel AMT (Active Management Technology) to enhance system performance. The options are **Enabled** and **Disabled**.

BIOS Hotkey Pressed

Select Enabled to use the BIOS Hotkey feature. The options are **Enabled** and **Disabled**.

Watch Dog

Select Enabled to allow AMT to reset or power down the system if the operating system or BIOS hangs or crashes. The options are **Disabled**, and **Enabled**.

OS Timer / BIOS Timer

These options appear if Watch Dog Timer (above) is enabled. This is a timed delay in seconds, before a system power down or reset after a BIOS or operating system failure is detected. Directly enter the value in seconds.

Serial Port Console Redirection

COM1 Console Redirection Console Redirection

Select Enabled to enable console redirection support for a serial port specified by the user.

The options are Enabled and Disabled.

*If the item above set to Enabled, the following items will become available for user's configuration:

COM1 Console Redirection Settings

This feature allows the user to specify how the host computer will exchange data with the client computer, which is the remote computer used by the user.

COM1 Terminal Type

This feature allows the user to select the target terminal emulation type for Console Redirection. Select VT100 to use the ASCII Character set. Select VT100+ to add color and function key support. Select ANSI to use the Extended ASCII Character Set. Select VT-UTF8 to use UTF8 encoding to map Unicode characters into one or more bytes. The options are **VT100**, **VT100+**, **VT-UTF8**, and **ANSI**.

COM1 Bits Per second

Use this feature to set the transmission speed for a serial port used in Console Redirection. Make sure that the same speed is used in the host computer and the client computer. A lower transmission speed may be required for long and busy lines. The options are **9600**, **19200**, **38400**, **57600** and **115200** (bits per second).

COM1 Data Bits

Use this feature to set the data transmission size for Console Redirection. The options are **7 Bits** and **8 Bits**.

COM1 Parity

A parity bit can be sent along with regular data bits to detect data transmission errors. Select Even if the parity bit is set to 0, and the number of 1's in data bits is even. Select Odd if the parity bit is set to 0, and the number of 1's in data bits is odd. Select None if you do not want to send a parity bit with your data bits in transmission. Select Mark to add a mark as a parity bit to be sent along with the data bits. Select Space to add a Space as a parity bit to be sent with your data bits. The options are **None**, **Even**, **Odd**, **Mark** and **Space**.

COM1 Stop Bits

A stop bit indicates the end of a serial data packet. Select 1 Stop Bit for standard serial data communication. Select 2 Stop Bits if slower devices are used. The options are **1** and **2**.

COM1 Flow Control

Use this feature to set the flow control for Console Redirection to prevent data loss caused by buffer overflow. Send a Stop signal to stop sending data when the receiving buffer is full. Send a Start signal to start sending data when the receiving buffer is empty. The options are **None** and **Hardware RTS/CTS**.

COM1 VT-UTF8 Combo Key Support

Select Enabled to enable VT-UTF8 Combination Key support for ANSI/VT100 terminals. The options are **Disabled** and **Enabled**.

COM1 Recorder Mode

Select Enabled to capture the data displayed on a terminal and send it as text messages to a remote server. The options are **Disabled** and **Enabled**.

COM1 Resolution 100x31

Select Enabled for extended-terminal resolution support. The options are **Disabled** and **Enabled**.

COM1 Legacy OS Redirection Resolution

Use this feature to select the number of rows and columns used in Console Redirection for legacy OS support. The options are **80x24** and **80x25**.

COM1 Putty KeyPad

This feature selects the settings for Function Keys and KeyPad used for Putty, which is a terminal emulator designed for the Windows OS. The options are **VT100**, **LINUX**, **XTERMR6**, **SC0**, **ESCN**, and **VT400**.

COM1 Redirection After BIOS Post

Use this feature to enable or disable legacy console redirection after BIOS POST. When set to Bootloader, legacy console redirection is disabled before booting the OS. When set to Always Enable, legacy console redirection remains enabled when booting the OS. The options are **Always Enable** and **Bootloader**.

SOL/COM2 Console Redirection

Select Enabled to use the SOL port for Console Redirection. The options are **Enabled** and **Disabled**.

*If the item above set to Enabled, the following items will become available for user's configuration:

SOL/COM2 Console Redirection Settings

Use this feature to specify how the host computer will exchange data with the client computer, which is the remote computer used by the user.

COM2 Terminal Type

Use this feature to select the target terminal emulation type for Console Redirection. Select VT100 to use the ASCII Character set. Select VT100+ to add color and function key support. Select ANSI to use the Extended ASCII Character Set. Select VT-UTF8 to use UTF8 encoding to map Unicode characters into one or more bytes. The options are **ANSI**, **VT100**, **VT100+**, and **VT-UTF8**.

COM2 Bits Per second

Use this feature to set the transmission speed for a serial port used in Console Redirection. Make sure that the same speed is used in the host computer and the client computer. A lower transmission speed may be required for long and busy lines. The options are **9600**, **19200**, **38400**, **57600** and **115200** (bits per second).

COM2 Data Bits

Use this feature to set the data transmission size for Console Redirection. The options are **7 Bits** and **8 Bits**.

COM2 Parity

A parity bit can be sent along with regular data bits to detect data transmission errors. Select Even if the parity bit is set to 0, and the number of 1's in data bits is even. Select Odd if the parity bit is set to 0, and the number of 1's in data bits is odd. Select None if you do not want to send a parity bit with your data bits in transmission. Select Mark to add a mark as a parity bit to be sent along with the data bits. Select Space to add a Space as a parity bit to be sent with your data bits. The options are **None**, **Even**, **Odd**, **Mark** and **Space**.

COM2 Stop Bits

A stop bit indicates the end of a serial data packet. Select 1 Stop Bit for standard serial data communication. Select 2 Stop Bits if slower devices are used. The options are **1** and **2**.

COM2 Flow Control

Use this feature to set the flow control for Console Redirection to prevent data loss caused by buffer overflow. Send a Stop signal to stop sending data when the receiving buffer is full. Send a Start signal to start sending data when the receiving buffer is empty. The options are **None** and **Hardware RTS/CTS**.

COM2 VT-UTF8 Combo Key Support

Select Enabled to enable VT-UTF8 Combination Key support for ANSI/VT100 terminals. The options are **Disabled** and **Enabled**.

COM2 Recorder Mode

Select Enabled to capture the data displayed on a terminal and send it as text messages to a remote server. The options are **Disabled** and **Enabled**.

COM2 Resolution 100x31

Select Enabled for extended-terminal resolution support. The options are **Disabled** and **Enabled**.

COM2 Legacy OS Redirection Resolution

Use this feature to select the number of rows and columns used in Console Redirection for legacy OS support. The options are **80x24** and **80x25**.

COM2 Putty KeyPad

This feature selects Function Keys and KeyPad settings for Putty, which is a terminal emulator designed for the Windows OS. The options are **VT100**, **LINUX**, **XTERMR6**, **SCO**, **ESCN**, and **VT400**.

COM2 Redirection After BIOS Post

Use this feature to enable or disable legacy Console Redirection after BIOS POST. When set to Bootloader, legacy Console Redirection is disabled before booting the OS. When set to Always Enable, legacy Console Redirection remains enabled when booting the OS. The options are **Always Enable** and **Bootloader**.

EMS (Emergency Management Services) Console Redirection

Select Enabled to use a COM port selected by the user for EMS Console Redirection. The options are **Enabled** and **Disabled**.

*If the item above set to Enabled, the following items will become available for user's configuration:

EMS Console Redirection Settings

This feature allows the user to specify how the host computer will exchange data with the client computer, which is the remote computer used by the user.

Out-of-Band Management Port

The feature selects a serial port in a client server to be used by the Microsoft Windows Emergency Management Services (EMS) to communicate with a remote host server. The options are **COM1** and **SOL/COM2**.

Terminal Type

Use this feature to select the target terminal emulation type for Console Redirection. Select VT100 to use the ASCII character set. Select VT100+ to add color and function key support. Select ANSI to use the extended ASCII character set. Select VT-UTF8 to use UTF8 encoding to map Unicode characters into one or more bytes. The options are **VT100**, **VT100+**, **VT-UTF8**, and **ANSI**.

Bits Per Second

This item sets the transmission speed for a serial port used in Console Redirection. Make sure that the same speed is used in the host computer and the client computer. A lower transmission speed may be required for long and busy lines. The options are **9600**, **19200**, **57600**, and **115200** (bits per second).

Flow Control

Use this item to set the flow control for Console Redirection to prevent data loss caused by buffer overflow. Send a Stop signal to stop sending data when the receiving buffer is full. Send a Start signal to start sending data when the receiving buffer is empty. The options are **None**, **Hardware RTS/CTS**, and **Software Xon/Xoff**.

- Data Bits
- Parity
- Stop Bits

ACPI Settings

ACPI Sleep State

This feature selects the ACPI Sleep State that the system will enter into when the suspend button is activated. The options are **Suspend Disabled** and **S3 (Suspend to RAM)**.

High Precision Event Timer

Select Enabled to activate the High Performance Event Timer (HPET) that produces periodic interrupts at a much higher frequency than a Real-time Clock (RTC) does in synchronizing multimedia streams, providing smooth playback and reducing the dependency on other timestamp calculation devices, such as an x86 RDTSC Instruction embedded in the CPU. The High Performance Event Timer is used to replace the 8254 Programmable Interval Timer. The options are **Disabled** and **Enabled**.

WHEA Support

Select Enabled to support the Windows Hardware Error Architecture (WHEA) platform and provide a common infrastructure for the system to handle hardware errors within the Windows OS environment to reduce system crashes and to enhance system recovery and health monitoring. The options are **Enabled** and **Disabled**.

Trusted Computing Configuration

Security Device Support

If this feature and the TPM jumper on the motherboard are both set to Enabled, onboard security devices will be enabled for TPM (Trusted Platform Module) support to enhance data integrity and network security. Reboot the system for a change on this setting to take effect. The options are **Disabled** and **Enabled**.

TPM State

This feature changes the TPM State. The options are **Disabled** and **Enabled**.



Note The system will restart to change the TPM State.

Pending TPM operation

Use this item to schedule a TPM-related operation to be performed by a security device for system data integrity. Your system will reboot to carry out a pending TPM operation. The options are **None** and **TPM Clear**.

Device Select

Use this feature to select the TPM version. TPM 1.2 will restrict support to TPM 1.2 devices. TPM 2.0 will restrict support for TPM 2.0 devices. Select Auto to enable support for both versions. The default setting is **Auto**.

The following are informational status messages that indicate the current TPM State:

- TPM Enabled
- Status TPM Active Status
- TPM Owner Status

TXT Support

Intel TXT (Trusted Execution Technology) helps protect against software-based attacks and ensures protection, confidentiality and integrity of data stored or created on the system. Use this feature to enable or disable TXT Support. The options are **Disabled** and **Enabled**.

iSCSI Configuration

iSCSI Initiator Name

This feature allows the user to enter the unique name of the iSCSI Initiator in IQN format. Once the name of the iSCSI Initiator is entered into the system, configure the proper settings for the following items:

- Add an Attempt
- Delete Attempts
- Change Attempt order

Intel I210 Gigabit Network Connection - 00:25:90:5D:39:AF

NIC Configuration

Link Speed

Use this feature to specify the port speed used for the selected boot protocol. The options are **Auto Negotiated**, **10 Mbps Half**, **10 Mbps Full**, **100 Mbps Half**, and **100 Mbps Full**.

Wake On LAN

Select Enabled for Wake On LAN support, which will allow the system to wake up when an onboard LAN device receives an incoming signal. The options are **Disabled** and **Enabled**.

Blink LEDs

Use this feature to identify the physical network port by blinking the associated LED. Use the keyboard to select a value.

UEFI Driver

This item displays the UEFI driver version.

Adapter PBA

This item displays the Processor Bus Adapter (PBA) model number. The PBA number is a nine digit number (i.e., 010B00-000) located near the serial number.

Device Name

This item displays the adapter device name.

Chip Type

This item displays the network adapter chipset name.

PCI Device ID

This item displays the device ID number.

PCI Address

This item displays the PCI address for this computer. PCI addresses are 3 two-digit hexadecimal numbers.

Link Status

This item displays the connection status.

MAC Address

This item displays the MAC address for this computer. Mac addresses are 6 two-digit hexadecimal numbers.

Intel Ethernet Connection (H) I219-LM

00:25:90:5D:39:AE

NIC Configuration

Link Speed

Use this feature to specify the port speed used for the selected boot protocol. The options are **Auto Negotiated**, **10 Mbps Half**, **10 Mbps Full**, **100 Mbps Half**, and **100 Mbps Full**.

Wake On LAN

Select **Enabled** for Wake On LAN support, which will allow the system to wake up when an onboard LAN device receives an incoming signal. The options are **Disabled** and **Enabled**.

Blink LEDs

Use this feature to identify the physical network port by blinking the associated LED. Use the keyboard to select a value.

UEFI Driver

This item displays the UEFI driver version.

Adapter PBA

This item displays the Processor Bus Adapter (PBA) model number. The PBA number is a nine digit number (i.e., 010B00-000) located near the serial number.

Device Name

This item displays the adapter device name.

Chip Type

This item displays the network adapter chipset name.

PCI Device ID

This item displays the device ID number.

PCI Address

This item displays the PCI address for this computer. PCI addresses are 3 two-digit hexadecimal numbers.

Link Status

This item displays the connection status.

MAC Address

This item displays the MAC address for this computer. Mac addresses are 6 two-digit hexadecimal numbers.

Virtual MAC Address

This item displays the Virtual MAC address for this computer. Mac addresses are 6 two-digit hexadecimal numbers.

Event Logs

Use this feature to configure Event Log settings.

Change SMBIOS Event Log Settings

Enabling/Disabling Options SMBIOS Event Log

Change this item to enable or disable all features of the SMBIOS Event Logging during system boot. The options are **Enabled** and **Disabled**.

Erasing Settings

Erase Event Log

If No is selected, data stored in the event log will not be erased. Select Yes, Next Reset, data in the event log will be erased upon next system reboot. Select Yes, Every Reset, data in the event log will be erased upon every system reboot. The options are **No**, **Yes**, **Next reset**, and **Yes, Every reset**.

When Log is Full

Select Erase Immediately for all messages to be automatically erased from the event log when the event log memory is full. The options are **Do Nothing** and **Erase Immediately**.

SMBIOS Event Long Standard Settings

Log System Boot Event

This option toggles the System Boot Event logging to enabled or disabled. The options are **Disabled** and **Enabled**.

MECI

The Multiple Event Count Increment (MECI) counter counts the number of occurrences that a duplicate event must happen before the MECI counter is incremented. This is a numeric value. The default value is **1**.

METW

The Multiple Event Time Window (METW) defines number of minutes must pass between duplicate log events before MECI is incremented. This is in minutes, from 0 to 99. The default value is **60**.



Note After making changes on a setting, be sure to reboot the system for the changes to take effect.

View SMBIOS Event Log

This section displays the contents of the SMBIOS Event Log.

IPMI

Use this feature to configure Intelligent Platform Management Interface (IPMI) settings.

BMC Firmware Revision

This item indicates the IPMI firmware revision used in your system.

IPMI Status (Baseboard Management Controller)

This item indicates the status of the IPMI firmware installed in your system.

System Event Log

Enabling/Disabling Options SEL Components

Select Enabled for all system event logging at bootup. The options are **Enabled** and **Disabled**.

Erasing Settings

Erase SEL

Select Yes, On next reset to erase all system event logs upon next system reboot. Select Yes, On every reset to erase all system event logs upon each system reboot. Select No to keep all system event logs after each system reboot. The options are **No**, **Yes**, **On next reset**, and **Yes, On every reset**.

When SEL is Full

This feature allows the user to decide what the BIOS should do when the system event log is full. Select Erase Immediately to erase all events in the log when the system event log is full. The options are **Do Nothing** and **Erase Immediately**.



Note After making changes on a setting, be sure to reboot the system for the changes to take effect.

BMC Network Configuration

BMC Network Configuration

The BMC network information is only valid when the IPMI Function is enabled.

IPMI LAN Selection

This item displays the IPMI LAN setting. The default setting is **Failover**.

IPMI Network Link Status

This item displays the IPMI Network Link status. The default setting is **Shared LAN**.

Update IPMI LAN Configuration

Select **Yes** for the BIOS to implement all IP/MAC address changes at the next system boot. The options are **No** and **Yes**.

Configuration Address Source

This feature allows the user to select the source of the IP address for this computer. If **Static** is selected, you will need to know the IP address of this computer and enter it to the system manually in the field. If **DHCP** is selected, the BIOS will search for a DHCP (Dynamic Host Configuration Protocol) server in the network that is attached to and request the next available IP address for this computer. The options are **DHCP** and **Static**. The following items are assigned IP addresses automatically if DHCP is selected.

Current Configuration Address Source

This item displays the current configuration address for this computer.

Station IP Address

This item displays the Station IP address for this computer. This should be in decimal and in dotted quad form (i.e., 192.168.10.253).

Subnet Mask

This item displays the sub-network that this computer belongs to. The value of each three-digit number separated by dots should not exceed 255.

Station MAC Address

This item displays the Station MAC address for this computer. Mac addresses are 6 two-digit hexadecimal numbers.

Gateway IP Address

This item displays the Gateway IP address for this computer. This should be in decimal and in dotted quad form (i.e., 172.31.0.1).

IPMI Function Support

Use this feature to enable IPMI support. The options are **Enabled** and **Disabled**. When **Disabled**, the system powers on quickly by removing BIOS support for extended IPMI features. The **Disable** option is for applications that require faster power on time without using Update Manager (SUM) or extended IPMI features. The BMC network configuration in the BIOS setup is also invalid when IPMI Function Support is disabled. The general BMC function and motherboard health monitor such as fan control are still functioning when this option is disabled.

Security

This menu allows the user to configure the following security settings for the system.

Password Check

Select Setup for the system to check for a password at Setup. Select Always for the system to check for a password at bootup or upon entering the BIOS Setup utility. The options are **Setup** and **Always**.

Administrator Password

Press Enter to create a new, or change an existing Administrator password.

Secure Boot Menu

This section displays the contents of the following secure boot features:

- System Mode
- Secure Boot
- Vendor Keys

Secure Boot

Use this item to enable secure boot. The options are **Disabled** and **Enabled**.

Secure Boot Mode

Use this item to select the secure boot mode. The options are **Standard** and **Custom**.

CSM Support

Select Enabled to support the EFI Compatibility Support Module (CSM), which provides compatibility support for traditional legacy BIOS for system boot. The options are **Enabled** and **Disabled**.

Key Management

This submenu allows the user to configure the following Key Management settings.

Provision Factory Default Keys

Select Enabled to install the default Secure-Boot keys set by the manufacturer. The options are **Disabled** and **Enabled**.

Enroll All Factory Default Keys

Select Yes to install all default secure keys set by the manufacturer. The options are **Yes** and **No**.

Save All Secure Boot Variables

This feature allows the user to decide if all secure boot variables should be saved.

Platform Key (PK)

This feature allows the user to configure the settings of the platform keys.

Set New Key

Select Yes to load the new platform keys (PK) from the manufacturer's defaults. Select No to load the platform keys from a file. The options are **Yes** and **No**.

Key Exchange Key Set New Key

Select Yes to load the KEK from the manufacturer's defaults. Select No to load the KEK from a file. The options are **Yes** and **No**.

Append Key

Select Yes to add the KEK from the manufacturer's defaults list to the existing KEK. Select No to load the KEK from a file. The options are **Yes** and **No**.

Authorized Signatures Set New Key

Select Yes to load the database from the manufacturer's defaults. Select No to load the DB from a file. The options are **Yes** and **No**.

Append Key

Select Yes to add the database from the manufacturer's defaults to the existing DB. Select No to load the DB from a file. The options are **Yes** and **No**.

Forbidden Signatures Set New Key

Select Yes to load the DBX from the manufacturer's defaults. Select No to load the DBX from a file. The options are **Yes** and **No**.

Append Key

Select Yes to add the DBX from the manufacturer's defaults to the existing DBX. Select No to load the DBX from a file. The options are **Yes** and **No**.

Authorized TimeStamps Set New Key

Select Yes to load the DBT from the manufacturer's defaults. Select No to load the DBT from a file. The options are **Yes** and **No**.

Append Key

Select Yes to add the DBT from the manufacturer's defaults list to the existing DBT. Select No to load the DBT from a file. The options are **Yes** and **No**.

Boot

Use this feature to configure Boot Settings:

Boot Mode Select

Use this item to select the type of device that the system is going to boot from. The options are Legacy, UEFI, and Dual. The default setting is **Dual**.

Fixed Boot Order Priorities

This option prioritizes the order of bootable devices that the system to boot from. Press <Enter> on each entry from top to bottom to select devices.

If the item above set to Legacy, UEFI/Dual the following items will be displayed:

- Legacy/UEFI/Dual/Boot Option #1
- Legacy/UEFI/Dual/Boot Option #2
- Legacy/UEFI/Dual/Boot Option #3
- Legacy/UEFI/Dual/Boot Option #4
- Legacy/UEFI/Dual/Boot Option #5
- Legacy/UEFI/Dual/Boot Option #6
- Legacy/UEFI/Dual/Boot Option #7
- Legacy/UEFI/Dual/Boot Option #8
- Legacy/UEFI/Dual/Boot Option #9
- Legacy/UEFI/Dual/Boot Option #10
- Legacy/UEFI/Dual/Boot Option #11
- Legacy/UEFI/Dual/Boot Option #12
- Legacy/UEFI/Dual/Boot Option #13
- Legacy/UEFI/Dual/Boot Option #14
- Legacy/UEFI/Dual/Boot Option #15

Delete Boot Option

Use this feature to remove a pre-defined boot device from which the system will boot during startup.

The settings are [any pre-defined boot device].

NETWORK Drive BBS Priorities

This feature allows the user to specify which Network devices are boot devices.

- Legacy Boot Order #1

UEFI NETWORK Drive BBS Priorities

This feature allows the user to specify which UEFI network drive devices are boot devices.

- UEFI Boot Order #1
- UEFI Boot Order #2

UEFI Application Boot Priorities

This feature allows the user to specify which UEFI devices are boot devices.

- UEFI Boot Order #1

Save & Exit

Select the Exit tab from the BIOS setup utility screen to enter the Exit BIOS Setup screen.

Discard Changes and Exit

Select this option to quit the BIOS Setup without making any permanent changes to the system configuration, and reboot the computer. Select Discard Changes and Exit from the Exit menu and press <Enter>.

Save Changes and Reset

When you have completed the system configuration changes, select this option to leave the BIOS setup utility and reboot the computer, so the new system configuration parameters can take effect. Select Save Changes and Exit from the Exit menu and press <Enter>.

Save Changes

After completing the system configuration changes, select this option to save the changes you have made. This will not reset (reboot) the system.

Discard Changes

Select this option and press <Enter> to discard all the changes and return to the AMI BIOS utility Program.

Default Options

Restore Optimized Defaults

To set this feature, select Restore Optimized Defaults from the Save & Exit menu and press <Enter>. These are factory settings designed for maximum system stability, but not for maximum performance.

Save As User Defaults

To set this feature, select Save as User Defaults from the Exit menu and press <Enter>. This enables the user to save any changes to the BIOS setup for future use.

Restore User Defaults

To set this feature, select Restore User Defaults from the Exit menu and press <Enter>. Use this feature to retrieve user-defined settings that were saved previously.

Boot Override

Listed on this section are other boot options for the system (i.e., Built-in EFI shell). Select an option and press <Enter>. Your system will boot to the selected boot option.

BIOS Error Beep Codes

Errors may occur during the Power-On Self-Test (POST) routines, which are performed each time the system is powered on.

Nonfatal errors are those which, in most cases, allow the system to continue the boot-up process. The error messages normally appear on the screen.

Fatal errors do not allow the system to continue the boot-up procedure. If a fatal error occurs, consult with your system manufacturer about possible repairs.

Table 2-1. BIOS Error Beep Codes

Beep Code	Error Message	Description
One beep	Refresh	Circuits have been reset. (Ready to power up.)
Five short beeps and one long beep	Memory error	No memory is detected in the system
One beep per device	Refresh	One beep for each USB device detected
One continuous beep	System overheat	System is overheating

OS Reinstallation and Recovery



Caution Recovering the OS using the hard drive-based recovery or the OS recovery USB erases the contents of your hard disk. Before recovering the OS, back up any files you want to keep.

The RMC-8356 includes a preinstalled OS from the factory. The RMC-8356 also includes two methods of restoring/reinstalling the OS to your system.

- Hard drive-based recovery stores a factory backup on a separate portion of your hard drive, allowing you to restore your server without additional media.



Note The hard drive recovery hot key is <F4>. To access the hard drive-based recovery tool, press and hold <F4> when video first appears during the boot process.



Note Hard drive recovery is *not* available if the OS is installed on a RAID array.

- The RMC-8356 may also ship with an OS recovery USB you can use to reinstall your operating system onto your hard drive.
If you need to reinstall your operating system, you can use the included OS recovery USB. Boot the RMC-8356 using the OS recovery USB to recover the OS.



Note You also may need to update or reinstall software after using the OS reinstallation USB to recover your OS. The OS reinstallation USB may contain drivers that are older or newer than the factory-installed version of the OS and may not contain the latest RAID drivers. To ensure you have the latest drivers, go to www.intel.com and install the Intel Rapid Storage Technology (Intel RST) RAID software package.



Note After you reinstall or recover your OS, you may find shortcuts on the desktop that require you to install specific drivers or software (for example, video drivers). Due to driver and software packaging, it was not possible to preinstall this software during the OS installation.

Cleaning



Caution *Always* disconnect the AC power cable before cleaning or servicing the chassis.

Exterior Cleaning



Caution Avoid getting moisture inside the chassis during exterior cleaning, especially through the top vents.

Do *not* wash the front- or rear-panel connectors or switches. Cover these components while cleaning the chassis.

Do *not* use harsh chemical cleaning agents; they may damage the chassis. Avoid chemicals that contain benzene, toluene, xylene, acetone, or similar solvents.

Clean the exterior surfaces of the chassis with a dry lint-free cloth or a soft-bristle brush. Do *not* use abrasive compounds on any part of the chassis.

Rack Mounting



Caution When mounting the equipment in the rack, do not create a hazardous condition due to uneven mechanical loading.

Installing the Rails

There are a variety of rack units on the market, which may require a slightly different assembly procedure.

The following is a basic guideline for installing the system into a rack with the rack mounting hardware provided. You should also refer to the installation instructions that came with the specific rack you are using.

Identifying the Rails

The rack rails and the related hardware should have been included with the system. Refer to Figure 2-1 to identify the rail sections.



Note The two rails are left/right specific.

Installing the Chassis Rails

Begin the rack mounting procedure by installing the inner rails to the server chassis.

1. Position the front and rear chassis rail sections along the side of the server making sure the screw holes line up. Note that these two rails are left/right specific.
2. Screw the front chassis rail (the long piece) securely to the side of the chassis. There should be two screws for each side. Repeat this procedure for the other rail on the opposite side of the chassis.
3. Attach the two rear chassis rails to the chassis in the same manner, again keeping in mind that the rails are left/right specific. (You will also need to attach the rail brackets when installing into a Telco rack.)



Caution Slide rail mounted equipment is not to be used as a shelf or a work space.

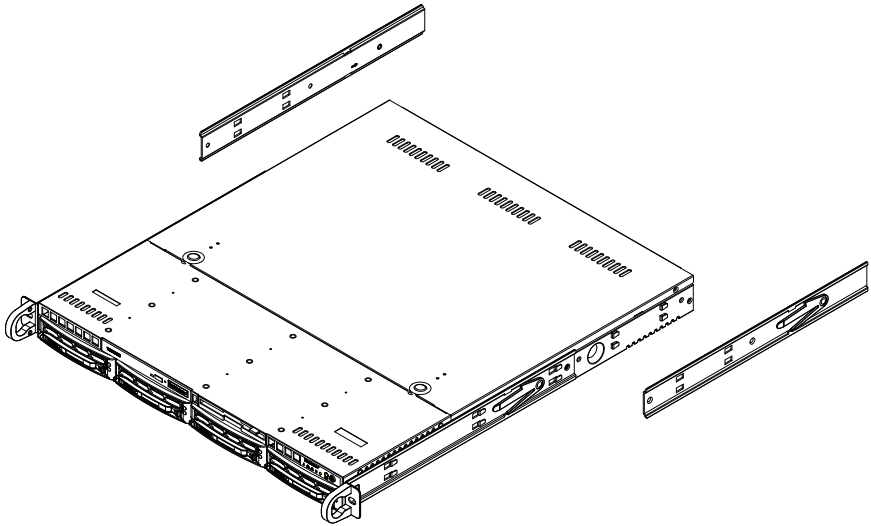

Caution Do not pick up the server with the front handles. They are designed to pull the system from a rack only.

Figure 2-1. Installing the Rear Inner Rails

Installing the Rack Rails

Determine where you want to place the server in the rack. Note that servers should always be installed to the bottom of a rack first for stability reasons.

1. Position the chassis rail guides at the desired location in the rack, keeping the sliding rail guide facing the inside of the rack.
2. Screw the assembly securely to the rack using the brackets provided.
3. Attach the other assembly to the other side of the rack, making sure that both are at the exact same height and with the rail guides facing inward.



Note Both front chassis rails and the rack rails have a locking tab, which serves two functions. First, it locks the server into place when installed and pushed fully into the rack (its normal operating position). In addition, these tabs lock the server in place when fully extended from the rack. This prevents the server from coming completely out of the rack when pulled out for servicing.

Installing the Server into a Rack

You should now have rails attached to both the chassis and the rack. The next step is to install the server into the rack.

1. Line up the rear of the chassis rails with the front of the rack rails.
2. Slide the chassis rails into the rack rails, keeping the pressure even on both sides (you may have to press the locking tabs when inserting).

3. When the server has been pushed completely into the rack, you should hear the locking tabs click.

Figure 2-2. Installing the Server into a Rack

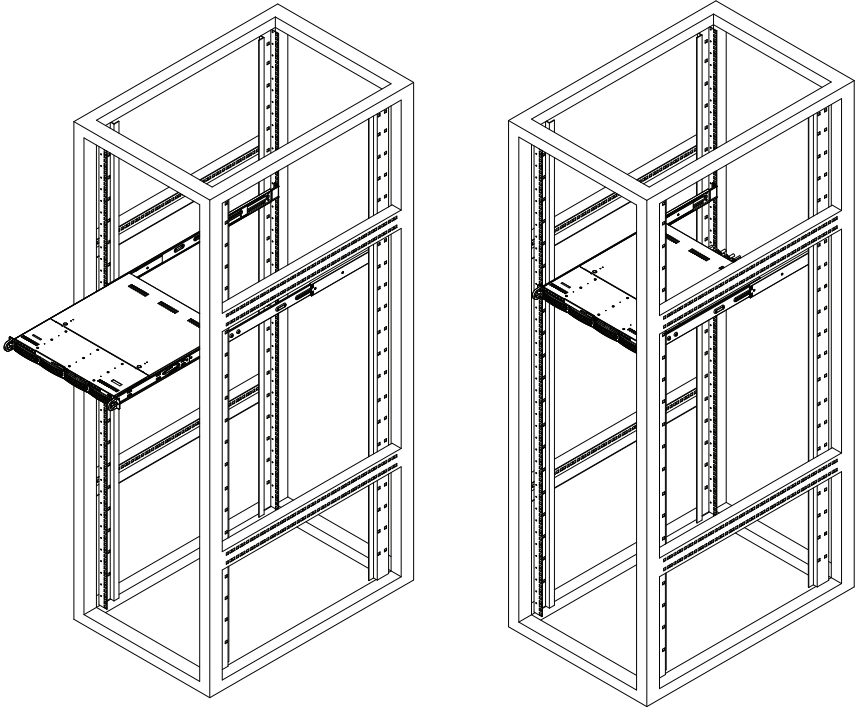

Note Figures are for illustrative purposes only. Always install servers to the bottom of a rack first.



Caution Stability hazard. The rack stabilizing mechanism must be in place, or the rack must be bolted to the floor before you slide the unit out for servicing. Failure to stabilize the rack can cause the rack to tip over.

Installing the Server into a Telco Rack

To install the SuperServer 5019S-M2 into a Telco (open) type rack, use two L-shaped brackets on either side of the chassis (four total).

1. First, determine how far the server will extend out from the front of the rack. The chassis should be positioned so that the weight is balanced between front and back.
2. Attach the two front brackets to each side of the chassis, then the two rear brackets positioned with just enough space to accommodate the width of the rack.

3. Finish by sliding the chassis into the rack and tightening the brackets to the rack.

Figure 2-3. Installing the Server into a Telco Rack

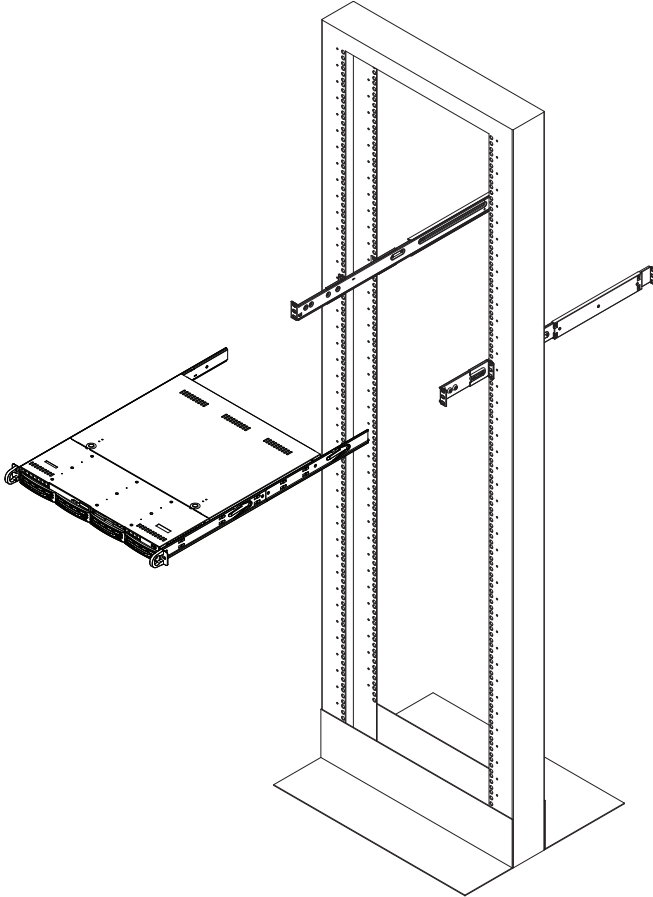

Note Figure is for illustrative purposes only. Always install servers to the bottom of a rack first.

I/O Information

This chapter describes the RMC-8356 I/O connectors.

Rear Panel Connectors

Serial

Two COM connectors (COM1 & COM2) are provided on the motherboard. Both are located near the PCI-E slot 4.

SATA

The motherboard includes a total of four SATA connectors, supported by the Intel C236 PCH chip. These SATA connectors support RAID 0 and 1.

Rear I/O

Refer to the following figure for locations and descriptions of the various I/O connectors on the rear of the motherboard.

Figure 3-1. Rear I/O Connectors

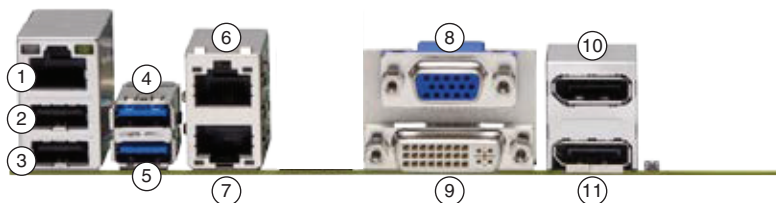

1	IPMI LAN	5	USB2 (3.0)	9	DVI
2	USB1 (2.0)	6	LAN2	10	DisplayPort2
3	USB0 (2.0)	7	LAN1	11	DisplayPort1
4	USB3 (3.0)	8	VGA (Disabled by default)		

LAN

There are two LAN connectors (LAN1/LAN2) on the I/O back panel. There is also a dedicated IPMI LAN connector on the I/O back panel. These connectors accept RJ45 type cables. Refer to the [LED Indicators](#) section of Appendix B, [Hardware Configuration](#), for more information.

Universal Serial Bus (USB)

There are two USB 2.0 connectors (USB0/1) and two USB 3.0 connectors (USB2/3) located on the I/O back panel. The motherboard also has three front access USB 2.0 headers (USB4/5, USB6/7, and USB8/9) and one front access USB 3.0 header (USB10/11). The USB12 header is USB Type A. The onboard headers can be used to provide front side USB access with a cable (not included).

Table 3-1. Front Panel USB (3.0/2.0) Pinout

Pin	Signal Name
1	VBUS
2	IntA_P2_SSRX-
3	IntA_P2_SSRX+
4	GND
5	IntA_P1_SSTX+
6	IntA_P1_SSTX+
7	GND
8	IntA_P1_D-
9	IntA_P1_D+
10	ID
11	IntA_P2_SSDX+
12	IntA_P2_SSDX-
13	GND
14	IntA_P2_SSTX+
15	IntA_P2_SSTX-
16	GND
17	IntA_P2_SSRX+
18	IntA_P2_SSRX-
19	VBus

Table 3-2. Front Panel USB 2.0 Header Pinout

Pin	Signal Name
1	+5 V
2	+5 V
3	USB_PN2
4	USB_PN3
5	USB_PP2
6	USB_PP3
7	Ground
8	Ground
9	Key
10	Ground

Table 3-3. Type A USB 10 (3.0) Pinout

Pin	Signal Name
1	VBUS
2	USB_N
3	USB_P
4	Ground
5	SSRX-
6	SSRX+
7	GND
8	SSTX-
9	SSTX+

VGA/DVI Port

A VGA connector and a DVI connector are located next to the LAN connector on the I/O back panel. Use these connections for VGA and DVI displays. The VGA connector is on top and the DVI is on the bottom.

DP (DisplayPort)

There are two DisplayPort connectors located on the rear I/O back panel. DisplayPort, developed by the VESA consortium, delivers digital display at a fast refresh rate. It can connect to virtually any display using a DisplayPort adapter for devices such as VGA, DVI, or HDMI.

MXI-Express Connectors

Refer to your MXI-Express hardware user manual for connector information.



Note To access the NI MXI-Express BIOS Compatibility Software, search for *MXI-Express BIOS Compatibility Software* at ni.com/drivers.

Common Configuration Questions

This chapter answers common configuration questions you may have when using the RMC-8356.

General Questions

What do the LEDs on the RMC-8356 front panel mean?

The power indicator lights when the main power is turned on. The LAN status LEDs flash to when there is activity on LAN1 and LAN2. The hard drive LED lights when there is hard drive activity on the RMC-8356. For more information, refer to Figure 1-1, [Front View of the RMC-8356](#).

How do I check the configuration of the memory, hard drive, time/date, and so on?

You can view these parameters in the BIOS setup. To enter the BIOS setup, reboot the RMC-8356 and press <Delete> during the memory tests. Refer to the [BIOS Setup](#) section of Chapter 2, [Installation and BIOS Setup](#), for more information.

Can I use the internal SATA drive and an external hard drive at the same time?

Yes.

What RAID modes are supported?

The RMC-8356 supports only RAID 0 and 1.

Does the RMC-8356 support a PCI card?

No, the RMC-8356 can support only PCI Express cards while using a riser card (provided).

What is the shortcut key to get to the boot menu while the BIOS is going through POST?

The shortcut key is <F11>.

Boot Options

What devices can I boot from?

The RMC-8356 can boot from the following devices:

- The internal SATA hard drive
- A network PXE server on the same subnet
- An external USB mass storage device such as a USB hard drive or CD-ROM



Note You should enable Legacy USB support to boot from USB devices. Refer to the *BIOS Setup* section of Chapter 2, *Installation and BIOS Setup*, for more information.

- An external USB floppy drive



Note There are some limitations when booting from a USB device. The RMC-8356 BIOS configures the USB devices so that they will work in a DOS environment.

How do I configure the controller to boot from these devices?

Press <Delete>, enter the BIOS, and select **Boot**. Set the order by device type and set the order for the devices listed within the device type. Refer to *BIOS Setup* in Chapter 2, *Installation and BIOS Setup*, for more information.

Chassis Configuration

How do I set up the RMC-8356 to work with my PXI chassis?

Configuration of the PXI system is handled through Measurement & Automation Explorer (MAX), included with the software pre-installed on your RMC-8356. MAX creates the `pxi-sys.ini` file, which defines the layout and parameters of your PXI system.

The configuration steps for single or multiple-chassis systems are the same. In MAX, select **Help»Help Topics»PXI** to configure your chassis.

The PXI specification allows many combinations of PXI chassis and system modules. To assist system integrators, the manufacturers of PXI chassis and system modules must document the capabilities of their products. The minimum documentation requirements are contained in `.ini` files, which consist of ASCII text. System integrators, configuration utilities, and device drivers can use these `.ini` files.

The capability documentation for the chassis is contained in a `chassis.ini` file provided by the chassis manufacturer. The information in this file is combined with information about the system controller to create a single system initialization file called `pxisys.ini` (PXI System Initialization). The RMC-8356 uses MAX to generate the `pxisys.ini` file from the `chassis.ini` file.

Device drivers and other utility software read the `pxisys.ini` file to obtain system information. For detailed information about initialization files, refer to the PXI specification at www.pxisa.org.

Upgrade Information

How do I upgrade system memory?

Refer to the [Upgrading Memory](#) section in Appendix B, *Hardware Configuration*.

How to I upgrade my hard drive or solid state disk?

Refer to the [Upgrading and Replacing Hard Disk Drives](#) section of Appendix B, *Hardware Configuration*.

How do I flash a new BIOS?

To see if the latest BIOS is available, go to ni.com/downloads.

Where do I get the latest software drivers?

The latest National Instruments software is available from ni.com/downloads.

What upgrade options are available for the RMC-8356?

Table 4-1 lists the available upgrade options.

Table 4-1. RMC-8356 Upgrade Options

Orderable P/N	Description
785651-01	Spare 1 TB HDD
785652-01	Spare 16 GB DDR4 memory module

Troubleshooting

This chapter answers common troubleshooting questions you may have when using the RMC-8356.

What if the RMC-8356 does not boot?

Several problems can cause a controller not to boot. Here are some things to look for and possible solutions.

Things to Notice:

- Which LEDs come on? The power indicator LED should stay lit. The hard disk drive LEDs should blink during boot as the disk is accessed.
- What appears on the display? Does it hang at some particular point (BIOS, Operating System, and so on)? If nothing appears on the screen, try a different monitor. Does your monitor work with a different PC? If it hangs, note the last screen output that you saw for reference when consulting National Instruments technical support.
- What has changed about the system? Did you recently move the system? Was there electrical storm activity? Did you recently add a new module, memory chip, or piece of software?
- Has the system overheated? If the Overheat/FanFail LED is lit, this indicates overheating. Unplug the AC power cord from the controller and allow it to cool down before powering it on again.

Things to Try:

- Make sure the RMC-8356 is plugged in to a working power source.
- Remove any nonessential cables or devices.
- Make sure the CPU and memory modules are properly seated in their slots.
- Clear the CMOS. (Refer to the [CMOS Clear](#) section of Appendix B, [Hardware Configuration](#).)
- Recover the hard drive on the RMC-8356. (Refer to the [OS Reinstallation and Recovery](#) section of Chapter 2, [Installation and BIOS Setup](#).)

My RMC-8356 boots fine until I get to Windows, at which point I cannot read the screen. This may include garbled output, white screen, black screen, or an out of synch message from the monitor.

This problem usually results from having the video card output set past the limits of the monitor. You will need to boot Windows in Safe Mode. To do this, reboot the RMC-8356. As Windows begins to boot, hold down <F8>. You should now be able to reset the video driver to lower set-

tings. Try setting the resolution to 640×480 and the refresh rate to 60 Hz. Once you reboot, you can raise these values again, using the test option in Windows. These settings are accessible through the **Advanced** tab of the **Display** item in the **Control Panel**. Alternately, you can try a different monitor, preferably a newer and larger one.

My system boots fine as long as a particular module is not in my chassis.

The most common cause of this is a damaged module. Try the module in a different chassis or with a different controller. Also, remove any external cables or terminal blocks connected to the system. If the module does not work in these cases, it is likely damaged. Contact the module manufacturer for further troubleshooting.

Refer to the KnowledgeBase or product manuals section at ni.com for more information specific to the chassis and module with which you are having difficulties.

How do I set Windows to prompt me before shutting down when I press the power button?

Select **Start»Control Panel»Power Options** to open the **Power Options Properties** window. Select **Choose what the power buttons do**. Under the Power and sleep button settings, use the drop down menu next to **When I press the power button** to select from **Do nothing**, **Sleep**, **Hibernate**, **Shut down**, or **Turn off the display**. Click **Save Changes**.

Specifications

This appendix lists the RMC-8356 electrical, mechanical, and environmental specifications.

Electrical

AC Input

Input voltage range	100 VAC to 240 VAC
Operating voltage range	90 VAC to 264 VAC
Input frequency	50 Hz/60 Hz
Operating frequency range	47 Hz to 63 Hz
Input current rating	4.2 A max
Power disconnect	The AC power cable provides main power disconnect. Depressing the front panel power switch enables or inhibits the internal power supply.



Caution Using the RMC-8356 in a manner not described in this document may impair the protection the RMC-8356 provides.

Mainboard

Socket	LGA 1151
Chipset	Intel C236 chipset
Memory slots	4 x Dual Channel DDR4 UDIMM, unbuffered ECC/Non-ECC
PCI Express	1 x PCI Express 3.0 x16 slot
SATA	4 x 3.5 in. Hot-Swappable SATA3 Bays
USB ports	2 x USB 2.0 ports (Rear) 4 x USB 3.0 (2 Rear, 2 Front)

Video	2 x Display Port 1 x DVI-I 1 x VGA (disabled by default)
Serial	RS-232 serial port
LAN	2 x Gigabit Ethernet RJ45, 1 x Dedicated IPMI RJ45
Onboard LAN controller	Intel i219LM + i210AT Dual-Port Gigabit Ethernet controller

CPU

CPU	Xeon E3-1275-V5
Clock speed	3.6 GHz
Max turbo frequency	4 GHz
Intel Smart Cache	8 MB
Package	LGA 1151

Hard Disk Drive

Capacity	1 TB 3.5 in. with 3 additional 3.5 in. drive bays for expansion
Interface	Serial-ATA 3

Memory

Standard memory	1 x 16 GB DDR4 SDRAM, UDIMM ECC 2133MHz
Max configurable upgrade	64 GB (4 x 16 GB) DDR4 SDRAM, UDIMM ECC 2133MHz

Mechanical

Overall dimensions (standard chassis)	
Height	1U
Width	437 mm (17.2 in.)

Depth	508 mm (20.0 in.)
Weight	8 kg (17.6 lbs)

Environmental



Caution If installed in a closed or multiunit rack assembly, the rack environment operating ambient temperature may be greater than room ambient temperature. Therefore, install the equipment in an environment compatible with the maximum ambient temperature (T_{ma}) the manufacturer specifies.

Operating temperature	10 to 35 °C (Tested in accordance with IEC 60068-2-1.)
Storage temperature	-40 to 60 °C (Tested in accordance with IEC 60068-2-1 and IEC 60068-2-2.)
Relative humidity (Tested in accordance with IEC 60068-2-56)	
Operating	8 to 90% noncondensing
Nonoperational (storage)	5 to 95% noncondensing
Operating location	Indoor use only
Maximum altitude	2,000 m
Installation Category	II
Pollution Degree	2

Acoustic Emissions

Sound pressure level (at front bystander position)

Minimum	53.1 dBA
Maximum	61.4 dBA

Safety

This product is designed to meet the requirements of the following standards of safety for information technology equipment:

- IEC 60950-1, EN 60950-1
- UL 60950-1, CSA 60950-1



Caution Overloading the circuits may damage supply wiring. Do not exceed the ratings on the equipment nameplate when connecting equipment to the supply circuit.



Note For UL and other safety certifications, refer to the product label or the [Online Product Certification](#) section.

Electromagnetic Compatibility

This product meets the requirements of the following EMC standards for electrical equipment for digital devices and information technology equipment:

- EN 55032 (CISPR 32): Class A emissions
- EN 55024 (CISPR 24): Immunity
- AZ/NZS CISPR 32: Class A Emissions
- FCC 47 CFR Part 15B: Class A emissions
- ICES-003: Class A emissions



Note In the United States (per FCC 47 CFR), Class A equipment is intended for use in commercial, light-industrial, and heavy-industrial locations. In Europe, Canada, Australia and New Zealand (per CISPR 32) Class A equipment is intended for use only in non-residential locations.



Note For EMC declarations and certifications, and additional information, refer to the [Online Product Certification](#) section.

CE Compliance

This product meets the essential requirements of applicable European Directives as follows:

- 2014/35/EU; Low-Voltage Directive (safety)
- 2014/13/EU; Electromagnetic Compatibility Directive (EMC)

Online Product Certification

Refer to the product Declaration of Conformity (DoC) for additional regulatory compliance information. To obtain product certifications and the DoC for this product, visit ni.com/certification, search by model number or product line, and click the appropriate link in the Certification column.

Environmental Management

NI is committed to designing and manufacturing products in an environmentally responsible manner. NI recognizes that eliminating certain hazardous substances from our products is beneficial to the environment and to NI customers.

For additional environmental information, refer to the *Minimize Our Environmental Impact* web page at ni.com/environment. This page contains the environmental regulations and directives with which NI complies, as well as other environmental information not included in this document.

Waste Electrical and Electronic Equipment (WEEE)



EU Customers At the end of the product life cycle, all products *must* be sent to a WEEE recycling center. For more information about WEEE recycling centers, National Instruments WEEE initiatives, and compliance with WEEE Directive 2012/19/EC on Waste and Electronic Equipment, visit ni.com/environment/weee.

Battery Replacement and Disposal



Battery Directive This device contains a long-life coin cell battery. If you need to replace it, use the Return Material Authorization (RMA) process or contact an authorized National Instruments service representative. For more information about compliance with the EU Battery Directive 2006/66/EC about Batteries and Accumulators and Waste Batteries and Accumulators, visit ni.com/environment/batterydirective.

电子信息产品污染控制管理办法（中国 RoHS）



中国客户 National Instruments 符合中国电子信息产品中限制使用某些有害物质指令 (RoHS)。关于 National Instruments 中国 RoHS 合规性信息，请登录 ni.com/environment/rohs_china。(For information about China RoHS compliance, go to ni.com/environment/rohs_china.)

Hardware Configuration

This appendix describes how to configure and upgrade the RMC-8356 hardware.



Caution No user (operator) serviceable parts are inside the RMC-8356.

The hardware configuration and upgrade procedures described in this appendix *must* be performed only by a qualified service technician.

Disconnect the power cord before servicing.

Motherboard Layout

The following is a layout of the RMC-8356 motherboard with jumper, connector, and LED locations shown. Refer the following tables for descriptions. For detailed descriptions, pinout information and jumper settings, refer to the [Power Connections](#) section.

Figure B-1 shows the key features of the RMC-8356 mainboard.

Figure B-1. RMC-8356 Mainboard Layout

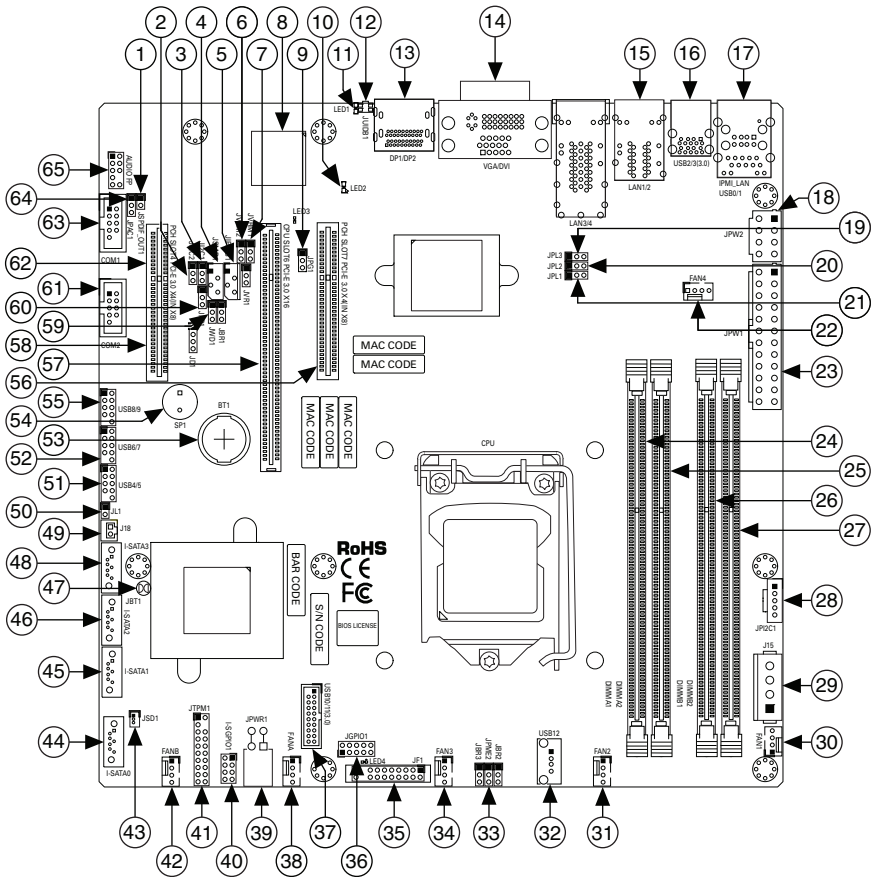

1	JSPDIF_OUT	18	JPW2	34	Fan3	50	JL1
2	JI2C2	19	JPL3	35	JF1	51	USB4/5
3	JI2C1	20	JPL2	36	JGPI01	52	USB6/7
4	JSMB1	21	JPL1	37	USB10/11 (3.0)	53	BT1
5	JIPMB1	22	FAN4	38	FANA	54	SP1
6	JVRM1	23	JPW1	39	JPWR1	55	USB8/9
7	JVRM2	24	DIMMB1	40	I-SGPIO1	56	SLOT7
8	LED3	25	DIMMA2	41	JTPM1	57	SLOT6
9	JPG1	26	DIMMB1	42	FANB	58	JD1
10	LED2	27	DIMMB2	43	JSD1	59	JWD1
11	LED1	28	JPI2C1	44	I-SATA0	60	JPB1
12	JUIDB1	29	J15	45	I-SATA1	61	COM2
13	DP1/DP2	30	Fan1	46	I-SATA2	62	SLOT4
14	VGA/DVI	31	Fan2	47	JBT1	63	SLOT6
16	LAN1/2	32	USB12	48	I-SATA3	64	COM1
17	USB 2/3	33	JPME2	49	J18	65	Audio FP
17	IPMI_LAN, USB0/1						



Note Figure B-1 shows three motherboard layouts. The motherboard has the features shown above except for the LAN3 and LAN4 ports and their associated jumpers.



Note Jumpers not identified are for test purposes only.



Caution There is a danger of explosion if the onboard battery is installed upside down (which reverses its polarities). This battery must be replaced only with the same or an equivalent type recommended by the manufacturer (CR2032).

Table B-1. Jumper Descriptions

Jumper	Description	Default Setting
JBT1	CMOS clear	Open (Normal)
J1 ² C1/J1 ² C2	SMB to PCI Express slots Enable/Disable	Pins 1-2 (Enabled)
JPB1	BMC Enable/Disable	Pins 1-2 (Enabled)
JPG1	VGA Enable/Disable (Disabled by default)	Pins 1-2 (Enabled)
JPL1/JPL2	LAN1/2 Enable/Disable	Pins 1-2 (Enabled)
JPME2	Manufacturing Mode	Pins 1-2 (Normal)
JVRM1	VRM SMB Clock (to BMC or PCH)	Pins 1-2 (BMC, Normal)
JVRM2	VRM SMB Data (to BMC or PCH)	Pins 1-2 (BMC, Normal)
JWD1	Watchdog	Pins 1-2 (Reset)



Caution To prevent damage to the power supply or motherboard, use a power supply with a 24-pin and one 8-pin power connectors. Be sure to connect these connectors to the 24-pin (JPW1) and one 8-pin (JPW2) power connectors on the motherboard. Failure to do so voids the manufacturer warranty on your power supply and motherboard.



Note When the LED4 LED is on, the onboard power connection is on. Be sure to unplug the power cables before removing or installing components.

Table B-2. Connector Descriptions

Connector	Description
AUDIO FP	Audio Front Panel Header
BT1	Onboard Battery
COM1/COM2	COM Headers
DP1/DP2	DisplayPorts
FAN1 ~ FAN4	System/CPU Fan Headers
FANA, FANB	I/O Fan Headers
IPMI_LAN	Dedicated IPMI LAN Port
I-SATA0 ~ I-SATA3	Intel® PCH SATA 3.0 Ports
I-SGPIO1	Serial Link General Purpose I/O Header
J15	4-pin Connector for HDD (to provide power from the motherboard to onboard devices)
J18	Extended CMOS Battery Connector
JD1	Speaker/Buzzer Header
JF1	Front Panel Control Header
JGPIO1	General Purpose I/O Header
JIPMB1	4-pin BMC External I2C Header
JL1	Chassis Intrusion Header
JPI2C1	Power Supply SMBbus I2C Header
JPW1	24-pin ATX Power Connector
JPW2	2V DC power for CPU (or alternative power for special enclosure when the 24-pin ATX power is not in use)
JPWR1	4-pin 12 V Power Connector
JSD1	SATA DOM Power Connector
JSMB1	PCH SMBus Header
JSPDIF_OUT1	Sony/Phillips Digital Interface Audio Output Header
JTPM1	Trusted Platform Module/Port 80 Connector

Table B-2. Connector Descriptions (Continued)

Connector	Description
JUIDB1	UID Switch
LAN1/LAN2	Gigabit Ethernet (RJ45) Ports
SLOT4	PCI-Express 3.0 x4 (in x8) Slot (supported by Intel PCH)
SLOT6	PCI-Express 3.0 x16 Slot (supported by the CPU)
SLOT7	PCI-Express 3.0 x4 (in x8) Slot (supported by Intel PCH)
SP1	Internal Speaker/Buzzer
USB0/1	Back Panel Universal Serial Bus (USB) 2.0 Ports
USB2/3	Back Panel Universal Serial Bus (USB) 3.0 Ports
USB4/5, 6/7, 8/9	Front Access USB 2.0 Headers
USB10/11	Front Access USB 3.0 Header
USB12	USB Type A Header
VGA/DVI	Back Panel VGA Port, DVI Port

Table B-3. LED Descriptions

LED	Description	Status
LED1	Unit ID LED	Blue Solid On: Unit Identified
LED2	Overheat/PWR Fail/Fan Fail LED	Red Solid On: Overheat Red Blinking: PWR Fail or Fan Fail
LED3	BMC Heartbeat LED	Green Blinking: BMC Normal
LED4	Power On LED	Green Solid On: System is On/Running

Front Control Panel Connector (JF1)

JF1 contains header pins for various control panel connections. Refer to the following figure for pin locations and definitions of the control panel buttons and LED indicators.

All JF1 wires have been bundled into a single cable to simplify this connection. Make sure the red wire plugs into pin 1 as marked on the motherboard. The other end connects to the control panel PCB board.

Figure B-2. JF1 Header Pins

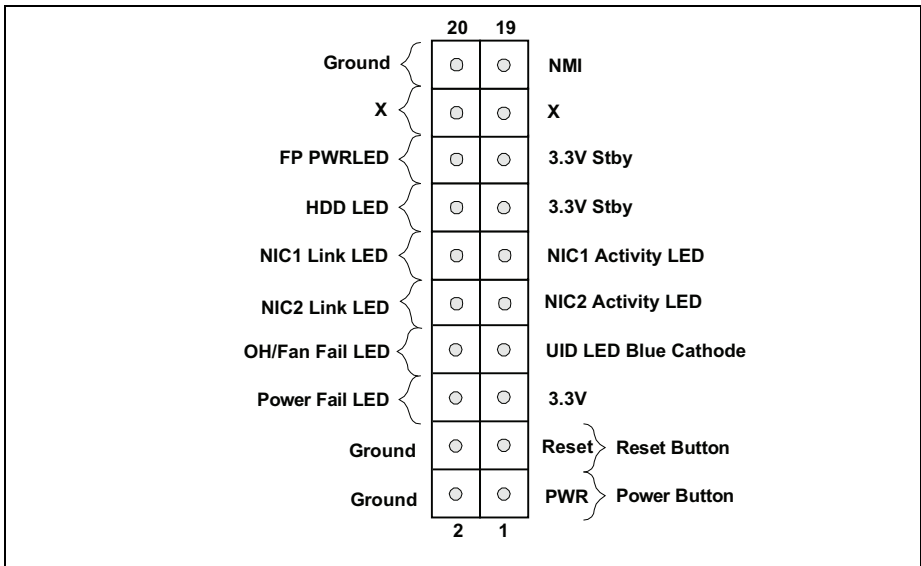

Motherboard Connections

This section describes the connections on the motherboard and provides pinout definitions. Note that depending on how the system is configured, not all connections are required. The LEDs on the motherboard are also described here. A severboard layout indicating component locations may be found in Appendix B.

Refer to the *Safety Information* section of Chapter 2, *Hardware Configuration*, before installing or removing components.

Power Connections

Two power connections on the motherboard must be connected to the power supply. The wiring is included with the power supply.

- 24-pin Primary ATX Power (JPW1)
- 8-pin Processor Power (JPW2)
- CMOS Battery Power (J18)

ATX Main Power Connector

The primary power connector (JPW1) meets the ATX SSI EPS 12 V specification. You must also connect the 8-pin (JPW2) processor power connector to your power supply.

Table B-4. ATX Main Power 24-pin Connector Pin Definitions

Pin	Definition	Pin	Definition
13	+3.3 V	1	+3.3 V
14	-12 V	2	+3.3 V
15	Ground	3	Ground
16	PS_ON	4	+5 V
17	Ground	5	Ground
18	Ground	6	+5 V
19	Ground	7	Ground
20	Res (NC)	8	PWR_OK
21	+5 V	9	5VSB
22	+5 V	10	+12 V
23	+5 V	11	+12 V
24	Ground	12	+3.3 V
Required Connection			



Note To provide adequate power to the motherboard, connect the 24-pin and the 8-pin power connectors to the power supply. Failure to do so may void the manufacturer's warranty on your power supply and motherboard.

Processor Power Connector

The 8-pin JPW2 must also be connected to the power supply. This connector is used to power the processor(s).

Table B-5. +12 V 8-Pin Power Pin Definitions

Pin	Definition
1-4	Ground
5-8	+12 V
Required Connection	

4-pin 12 V Power Connector

JPWR1 is a 4-pin 12 V power connector that provides alternative power.

Table B-6. 4-Pin Power Pin Definitions

Pin	Definition
1-2	Ground
3-4	+12 V

Extended CMOS Battery Connector

J18 is a secondary power connector that provides power to the CMOS battery.

Table B-7. CMOS Battery Connector Pin Definitions

Pin	Definition
1	VBAT
2	Ground
Required Connection	

4-pin HDD Power Connector

J15 is a 4-pin power connector that provides power to onboard HDD devices. Refer to the following table for pin definitions.

Table B-8. 4-Pin HDD Power Pin Definitions

Pin	Definition
1	12 V
2	GND
3	GND
4	5 V

Headers and Connectors

Fan Headers

There are six fan headers on the motherboard. These are 4-pin fan headers; pins 1-3 are backward compatible with traditional 3-pin fans. The onboard fan speeds are controlled by Thermal Management via IPMI. When using Thermal Management setting, please use all 3-pin fans or all 4-pin fans.

Table B-9. Fan Header Pin Definitions

Pin	Definition
1	Ground (Black)
2	2.5 A/+12 V (Red)
3	Tachometer
4	PWM_Control

Speaker/Buzzer

On the JD1 header, pins 1-4 are for the speaker and pins 3-4 are for the buzzer. If you wish to use an external speaker, connect its cable to pins 1-4.

Table B-10. Speaker Connection Pin Definitions

Pin Setting	Definition
Pins 1-4	Speaker
Pins 3-4	Buzzer

SGPIO Headers

The I-SGPIO1 (Serial General Purpose Input/Output) header is used to communicate with the enclosure management chip on the backplane.

Table B-11. SGPIO Header Pin Definitions

Pin	Definition	Pin	Definition
1	NC	2	NC
3	GND	4	Data
5	Load	6	GND
7	Clock	8	NC
NC = No Connection			

General Purpose I/O Header

The JGPIO1 (General Purpose Input/Output) header is a general purpose I/O expander on a pin header via the SMBus.

Table B-12. JGPIO1 Header Pin Definitions

Pin	Definition	Pin	Definition
1	3.3 V Stby	2	GND
3	GP0	4	GP1
5	GP2	6	GP3
7	GP5	8	GP5
9	GP6	10	GP7

TPM/Port 80 Header

A Trusted Platform Module (TPM)/Port 80 header is located at JTPM1 to provide TPM support and Port 80 connection. A TPM is a security device that supports encryption and authentication in hard drives. It enables the motherboard to deny access if the TPM associated with the hard drive is not installed in the system.

Table B-13. Trusted Platform Module Header Pin Definitions

Pin	Definition	Pin	Definition
1	LCLK	2	GND
3	LFRAME#	4	<(Key)>
5	LRESET#	6	+5 V
7	LAD3	8	LAD2
9	+3.3 V	10	LAD1
11	LAD0	12	GND
13	SMB_CLK	14	SMB_DAT
15	+3 V Stby	16	SERIRQ
17	GND	18	CLKRUN#
19	LPCPD#	20	LDRQ#

Front Accessible Audio Header

A 10-pin audio header is provided on the motherboard. Connect an audio cable to this header for audio playback.

Table B-14. Audio Header Pin Definitions

Pin	Definition	Pin	Definition
1	Microphone_Left	6	Ground
2	Audio_Ground	7	Jack_Detect
3	Microphone_Right	8	Key
4	Audio_Detect	9	Line_2_Left
5	Line_2_Right	10	Ground

SPDIF_OUT

The SPDIF Out is header used for digital audio. You will also need the appropriate cable to use this feature.

Table B-15. SPDIF_Out Pin Definitions

Pin	Definition
1	SPDIF Out
2	Ground

Chassis Intrusion

A Chassis Intrusion header is located at JL1 on the motherboard. Attach the appropriate cable from the chassis to the header to inform you when the chassis has been opened.

Table B-16. Chassis Intrusion Pin Definitions

Pin	Definition
1	Intrusion Input
2	Ground

Internal Speaker/Buzzer

The Internal Speaker/Buzzer (SP1) is used to provide audible indications for various beep codes.

Table B-17. Internal Buzzer Pin Definitions

Pin	Definition	
1	Pos (+)	Beep In
2	Neg (-)	Alarm Speaker

Power SMB (I²C) Header

Power System Management Bus (I²C) header at JPI²C1 monitors the power supply, fan and system temperatures.

Table B-18. Power SMB Pin Definitions

Pin	Definition
1	Clock
2	Data
3	PMBUS_Alert
4	Ground
5	+3.3 V

4-pin BMC External I²C Header

A System Management Bus header for IPMI 2.0 is located at JIPMB1. Connect the appropriate cable here to use the IPMB I²C connection on your system.

Table B-19. External I²C Header Pin Definitions

Pin	Definition
1	Data
2	GND
3	Clock
4	NC

System Management Bus Header

A System Management Bus header for additional slave devices or sensors is located at JSMB1.

Table B-20. External I²C Header Pin Definitions

Pin	Definition
1	Data
2	Ground
3	Clock
4	No Connection

Disk-On-Module Power Connector

The Disk-On-Module (DOM) power connector at JSD1 provides 5 V power to a solid-state DOM storage device connected to one of the SATA ports.

Table B-21. DOM Power Pin Definitions

Pin	Definition
1	5 V
2	Ground
3	Ground

Unit Identifier Switch/UID LED Indicator

A Unit Identifier (UID) switch and an LED Indicator are located on the motherboard. The UID switch is located at JUIDB1, which is next to the DP port on the I/O back panel. The UID LED (LED1) is located next to the UID switch. When you press the UID switch, the UID LED will be turned on. Press the UID switch again to turn off the LED indicator. The UID Indicator provides easy identification of a system unit that may be in need of service.



Note UID can also be triggered via IPMI on the motherboard.

Table B-22. UID Switch Pin Definitions

Pin	Definition
1	Ground
2	Ground
3	Button In
4	Button In

Table B-23. UID LED Pin Definitions

Color	Status
Blue: On	Unit Identified

Pin Definitions

Power Button

The Power Button connection is located on pins 1 and 2 of JF1. Momentarily contacting both pins will power on/off the system. This button can also be configured to function as a suspend button. To turn off the power when the system is in suspend mode, press the button for 4 seconds or longer.

Table B-24. Power Button Pin Definitions (JF1)

Pin	Definition
1	Signal
2	Ground

Reset Button

The Reset Button connection is located on pins 3 and 4 of JF1. Attach it to a hardware reset switch on the computer case.

Table B-25. Reset Button Pin Definitions (JF1)

Pin	Definition
3	Reset
4	Ground

Power Fail LED

The Power Fail LED connection is located on pins 5 and 6 of JF1.

Table B-26. Power Fail LED Pin Definitions (JF1)

Pin	Definition
5	3.3 V
6	PWR Supply Fail

Overheat (OH)/Fan Fail

Connect an LED cable to pins 7 and 8 of JF1 to use the Overheat/Fan Fail LED connections.

Table B-27. OH/Fan Fail Indicator Status

Status	Definition
Off	Normal
On	Overheat
Flashing	Fan Fail

NIC1/NIC2 (LAN1/LAN2)

The NIC (Network Interface Controller) LED connection for LAN port 1 is located on pins 11 and 12 of JF1, and the LED connection for LAN Port 2 is on Pins 9 and 10. Attach the NIC LED cables here to display network activity.

Table B-28. LAN1/LAN2 LED Pin Definitions (JF1)

Pin	Definition
9/11	3.3 V Stby
10/12	LAN LED Active

HDD LED

The HDD LED connection is located on pins 13 and 14 of JF1. Attach a cable here to indicate the status of all HDD-related activity.

Table B-29. HDD LED Pin Definitions (JF1)

Pin	Definition
13	3.3 V Stby
14	HD Active

Power LED

The Power LED connection is located on pins 15 and 16 of JF1.

Table B-30. Power LED Pin Definitions (JF1)

Pin	Definition
15	3.3 V Standby
16	Power LED

NMI Button

The non-maskable interrupt button header is located on pins 19 and 20 of JF1.

Table B-31. NMI Button Pin Definitions (JF1)

Pin	Definition
19	Control
20	Ground

Jumpers

To modify the operation of the motherboard, jumpers are used to choose between optional settings. Jumpers create shorts between two pins to change the function associated with it. Pin 1 is identified with a square solder pad on the printed circuit board. See the motherboard layout page for jumper locations.



Note On a two-pin jumper, *closed* means the jumper is on both pins and *open* indicates the jumper is either on only one pin or has been completely removed.

CMOS Clear

JBT1 is used to clear the CMOS, which will also clear any passwords. Instead of pins, this jumper consists of contact pads to prevent accidentally clearing the contents of the CMOS.

Complete the following steps to clear the CMOS

1. First power down the system and unplug the power cord(s).
2. Remove the cover of the chassis to access the motherboard.
3. Remove the onboard battery from the motherboard.
4. Short the CMOS pads with a metal object such as a small screwdriver for at least four seconds.
5. Remove the screwdriver (or shorting device).
6. Replace the cover, reconnect the power cord(s) and power on the system.



Note Clearing the CMOS will also clear all passwords.



Caution Do not use the PW_ON connector to clear the CMOS.

LAN1/2 Enable/Disable

Change the setting of jumper JPL1 and JPL2 to enable or disable the LAN1 and LAN2 Ethernet ports, respectively. The default setting is **Enabled**.

Table B-32. LAN1/2 Jumper Settings

Jumper Setting	Definition
Pins 1-2	Enabled
Pins 2-3	Disabled

Watch Dog

JWD controls the Watch Dog function. Watch Dog is a monitor that can reboot the system when a software application hangs. Jumping pins 1-2 will cause Watch Dog to reset the system if an application hangs. Jumping pins 2-3 will generate a non-maskable interrupt signal for the application that hangs. Watch Dog must also be enabled in BIOS. The default setting is **Reset**.



Note When Watch Dog is enabled, the user needs to write their own application software to disable it.

Table B-33. Watch Dog Jumper Settings

Jumper Setting	Definition
Pins 1-2	Reset
Pins 2-3	NMI
Open	Disabled

SMBus to PCI Slots

Use jumpers JI2C1 and JI2C2 to connect the System Management Bus (I2C) to PCI-Express slots to improve PCI performance. These two jumpers should be set to the same setting. The default setting is **Enabled**.

Table B-34. I²C for PCIe Slots Jumper Settings

Jumper Setting	Definition
Pins 1-2	Enabled
Pins 2-3	Disabled

BMC Enabled

JPB1 allows you to enable or disable the BMC (Baseboard Management Control) chip and the onboard IPMI connection. This jumper is used together with the IPMI settings in the BIOS. If the BMC is disabled, IPMI health monitoring and remote management functions are no longer supported. The default setting is **BMC Enable**.

Table B-35. BMC Enabled Jumper Settings

Jumper Setting	Definition
Pins 1-2	BMC Enabled
Pins 2-3	Disabled

Manufacturer Mode Select

Close pins 2 and 3 of jumper JPME2 to bypass SPI flash security and force the system to operate in the manufacturer mode, which will allow the user to flash the system firmware from a host server for system setting modifications. The default setting is **Normal**.

Table B-36. Manufacturer Mode Jumper Settings

Jumper Setting	Definition
Pins 1-2	Normal
Pins 2-3	Manufacturer Mode

I2C Bus for VRM

Jumpers JVRM1 and JVRM2 allow the BMC or the PCH to access the PCU and memory VRM controllers. The default setting is **BMC**.

Table B-37. VRM Jumper Settings

Jumper Setting	Definition
Pins 1-2	BMC (Default)
Pins 2-3	PCH

LED Indicators

LAN LEDs

Each of the Ethernet LAN ports has two LEDs. One LED indicates activity when flashing while the other Link LED may be green, amber, or off to indicate the speed of the connection.

Table B-38. LAN Link LED State

LED Color	Definition
Off	No Connection/10 Mbps
Green	100 Mb/s
Green	1 Gb/s

Dedicated IPMI LAN LEDs

An IPMI LAN is also located on the rear I/O panel. The LED on the right indicates activity, while the LED on the left indicates the speed of the connection.

Table B-39. IPMI LAN LED

	LED Color	State
Off	Off	No Connection
Green: Solid	Link/Speed (Left)	100 Mb/s
Amber: Blinking	Activity (Right)	Active

Unit ID LED (UID)

A rear Unit ID LED (LED1) is located next to the I/O back panel. This UID indicator provides easy identification of a system unit that may be in need of service. Refer to the table for the LED status.

Table B-40. Unit ID LED Indicator

LED Color	Definition
Blue: On	Unit identified

BMC Heartbeat LED

A BMC Heartbeat LED is located at LED3 on the motherboard. When LED3 is blinking, the BMC is functioning normally.

Table B-41. BMC Heartbeat LED Indicator

LED Color	Definition
Green: Blinking	BMC: Normal

Onboard Power LED

The Onboard Power LED is located at LED4. When this LED is on, it means power is present on the motherboard. Be sure to turn off the system and unplug the power cord before removing or installing components.

Table B-42. Onboard Power LED Indicator

LED Color	Definition
Off	System Off (power cable not connected)
Green	System On

Overheat/PWR Fail/Fan Fail LED

An Overheat/PWR/Fail/ Fan Fail LED is located at LED2.

Table B-43. Overheat/PWR Fail/Fan Fail LED Indicator)

LED Color	Definition
Solid	Overheat
Blinking	PWR Fail or Fan Fail

Data Cables

The data cables in the system have been carefully routed to maintain airflow efficiency. If you disconnect any data cables, take care to re-route them as they were originally when reconnecting them.



Caution Ensure the cables do not come into contact with the fans.

Upgrading Memory

The mainboard supports 4 240-pin UDIMM ECC DDR4 SDRAM slots with maximum memory size of 64 GB. We recommend you purchase your DDR-4 UDIMM modules from National Instruments. Other off-the-shelf DDR-4 UDIMM modules are not guaranteed to work properly.

DIMM Module Population Sequence

When installing memory modules, the DIMM slots should be populated in the following order: DIMMB2, DIMMA2, DIMMB1, DIMMA1.

- Always use DDR4 DIMM modules of the same type, size and speed.
- Mixed DIMM speeds can be installed. However, all DIMMs will run at the speed of the slowest DIMM.
- The motherboard will support odd-numbered modules (1 or 3 modules installed). However, for best memory performance, install DIMM modules in pairs to activate memory interleaving.

Figure B-3. Populating DIMMs

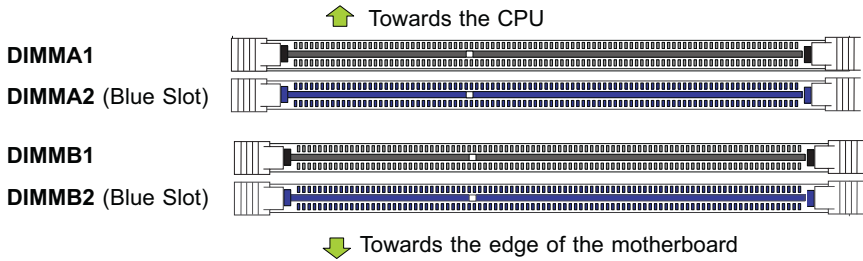

Note Memory upgrades are available from National Instruments under the following orderable part numbers:

- 1 × 16 GB DDR4 SDRAM for RMC-8356 (1 × 16 GB DIMM)

Part Number	Description
785652-01	16 GB SDRAM replacement/upgrade for RMC-8356

Memory Installation



Note National Instruments recommends using 16 GB DDR4 SDRAM, UDIMM ECC 2133 MHz memory modules purchased from National Instruments. Other off-the-shelf DDR4 UDIMM modules are not guaranteed to work properly.



Caution Exercise extreme care when installing or removing DIMM modules to prevent any possible damage. Also, note that the memory is interleaved to improve performance.

Memory Support

The RMC-8356 supports up to 64 GB registered UDIMM ECC DDR4 2133 MHz in 4 DIMMs. (Refer to ni.com for the recommended memory list.)

System Memory Allocation and Availability

Table B-44 lists possible system memory allocation and availability.

Table B-44. System Memory Allocation and Availability

System Device	Size	Physical Memory Available (4 GB Total System Memory)
Firmware hub flash memory (system BIOS)	1 MB	3.99 GB
Local APIC	4 KB	3.99 GB
Area reserved for the chipset	2 MB	3.99 GB
I/O APIC (4 KB)	4 KB	3.99 GB
PCI enumeration area 1	256 MB	3.76 GB
PCI Express (256 MB)	256 MB	3.51 GB
PCI enumeration area 2 (if needed) (aligned on 256 MB boundary)	512 MB	3.01 GB
VGA memory	16 MB	2.85 GB
TSEG	1 MB	2.84 GB
Memory available for the OS and other applications	—	2.84 GB

Installing DDR Modules

Follow these steps to install DDR modules:

1. Remove power from system.
2. Press the cover release buttons on the top of the RMC-8356.
3. Push the cover backward to remove it.

- Align the notch in the center of the DDR DIMM module with the key on the DIMM slot. Insert the module vertically into the slot and push it in until the pins are fully inserted, as shown below.

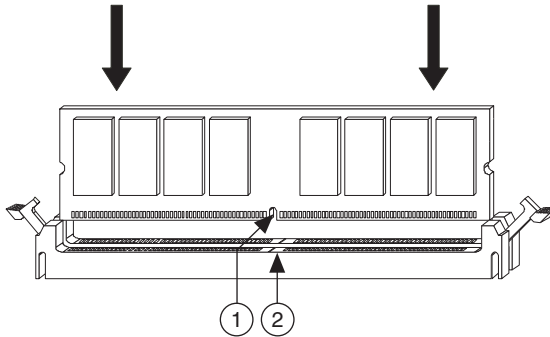

1 Notch

2 Key

- When the module is fully inserted, the plastic clip at each side of the slot automatically closes, as shown below.

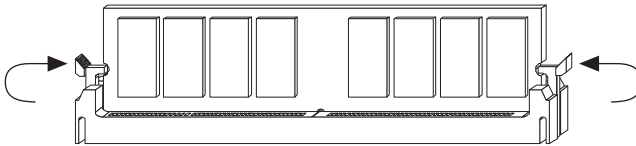

- Replace the RMC-8356 cover by sliding the cover forward. Make sure the safety lock fits firmly.

Removing DDR Modules

Follow these steps to remove DDR modules:

- Remove power from system.
- Open the plastic clips on both sides of the module.
- Remove the module from the slot.

Upgrading and Replacing Hard Disk Drives

Hard Drives

Your server may or may not have come with hard drives installed. Up to four 3.5" hard drives are supported by the chassis.

The SATA drives are mounted in drive carriers to simplify their installation and removal from the chassis. (Both procedures may be done without removing power from the system.)

Removing a Hot-Swap Drive Carrier

1. Push the release button on the carrier.
2. Swing the handle fully out.
3. Grasp the handle and use it to pull the drive carrier out of its bay.

Mounting a Drive in a Drive Carrier

1. To add a new drive, install it into the carrier with the printed circuit board side facing down so that the mounting holes align with those in the carrier.
2. Secure the drive to the carrier with the screws provided, then push the carrier completely into the drive bay. You should hear a *click* when the drive is fully inserted. This indicates that the carrier has been fully seated and connected to the midplane, which automatically makes the power and logic connections to the hard drive.

Figure B-4. Removing a Drive Carrier

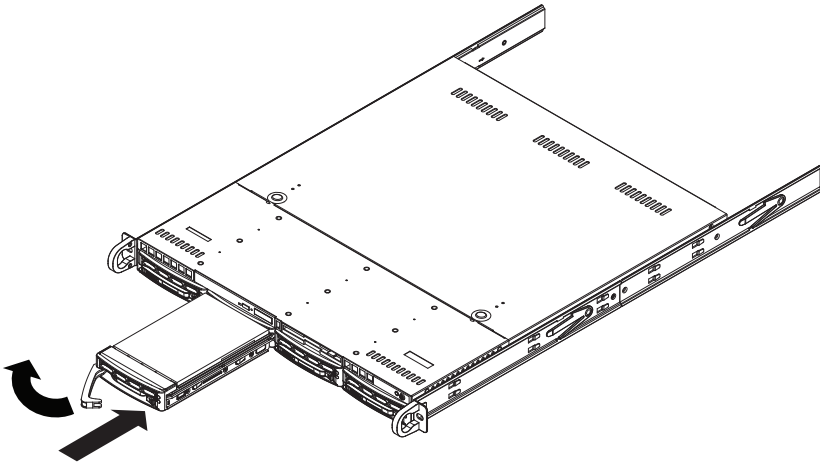

Removing a Drive from a Drive Carrier

1. Remove the screws that secure the hard drive to the carrier and separate the hard drive from the carrier.
2. Replace the carrier back into the drive bay.

Figure B-5. Mounting a Drive in a Carrier

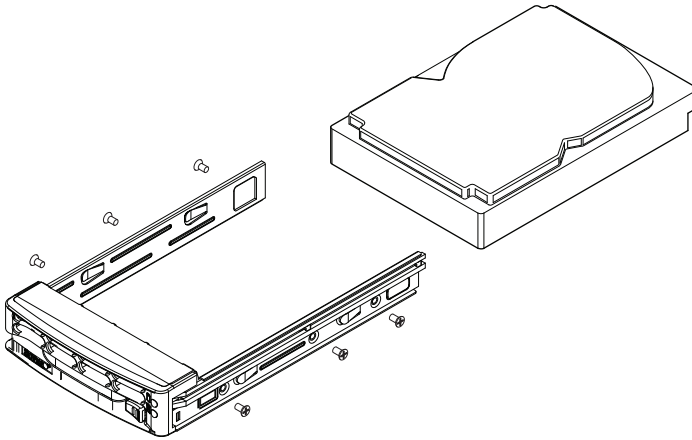

Hard Drive Carrier Indicators

Each hard drive carrier has two LED indicators: an activity indicator and a status indicator. In RAID configurations, the status indicator lights to indicate the status of the drive. In non-RAID configurations, the status indicator remains off. See the table below for details.

Table B-45.

Hard Drive Carrier LED Indicators		
LED	State/Condition	Indication
Green	Blinking	Drive activity
Red	Solid on	Drive failure



Note Enterprise level hard disk drives are recommended for use in NI chassis and servers.

Hard Drive Part Numbers

Use the part number in Table B-46 to order a spare/upgrade hard drive.

Table B-46. Hard Drive Part Numbers

Part Number	Description
785651-01	Spare 1 TB HDD for RMC-8356

PCI Expansion Card Installation

The system includes a pre-installed riser card that positions a standard size PCI-E x16 card at a 90 degree angle, allowing it to fit inside the chassis.

Installing PCI Expansion Cards

The CSE-RR1U-E16 riser card has already been pre-installed into the motherboard. Perform the following steps to install an add-on card:

Begin by removing power from the system.

1. Remove the chassis cover to access the inside of the system.
2. Remove the PCI slot shield on the chassis by releasing the locking tab.
3. Insert the expansion (add-on) card into the riser card.
4. Secure the card with the locking tab.

Motherboard Battery

The motherboard uses non-volatile memory to retain system information when system power is removed. This memory is powered by a lithium battery residing on the motherboard.

Replacing the Battery

Begin by removing power from the system.

1. Push aside the small clamp that covers the edge of the battery. When the battery is released, lift it out of the holder.
2. To insert a new battery, slide one edge under the lip of the holder with the positive (+) side facing up. Then push the other side down until the clamp snaps over it.

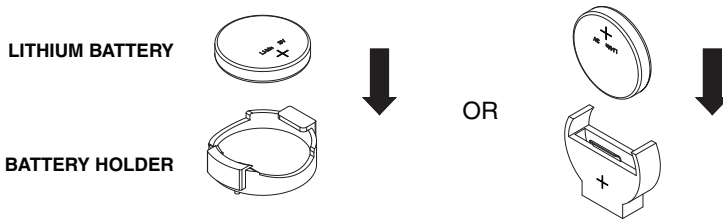

Note Please handle used batteries carefully. Do not damage the battery in any way; a damaged battery may release hazardous materials into the environment. Do *not* discard a used battery in the garbage or a public landfill. Please comply with the regulations set up by your local hazardous waste management agency to dispose of your used battery properly.

Figure B-6. Installing the Onboard Battery

Caution There is a danger of explosion if the onboard battery is installed upside down (which reverses its polarities). This battery must be replaced only with the same or an equivalent type recommended by the manufacturer (CR2032).

System Cooling

Four, 4 cm counter-rotating fans provide the cooling for the system. Each fan unit is actually made up of two fans joined back-to-back, which rotate in opposite directions. This counter-rotating action generates exceptional airflow and is effective in dampening vibration levels.

It is very important that the chassis top cover is installed for the cooling air to circulate properly through the chassis and cool the components.

Installing Fans

Fan speed is controlled by system temperature via IPMI. If a fan fails, the remaining fans will ramp up to full speed. The system will continue to operate, but at reduced performance. Replace any failed fan at your earliest convenience with the same type and model.

Complete the following steps to replace a system fan.

1. If necessary, open the chassis while the power is running to determine which fan requires replacement. Don *not* run the server for an extended period of time with the chassis open.
2. Power down the system and unplug the AC power cord from the rear of the power supply. Open the chassis cover.
3. Remove the failed fan's cable from the connector on the motherboard.
4. Gently pull upward to remove the failed fan from the housing.
5. Place the new fan into the vacant space in the housing. Make sure that the arrows on the side of the fan (indicating air direction) point in the same direction as the arrows on the other fans.
6. Connect the fan wires to the same fan header as the fan just removed.
7. Plug the power cord into the rear of the power supply, power up the system and check that the fan is working properly before replacing the chassis cover.

Intel SATA RAID Utility for Intel C236

This appendix describes the Intel SATA RAID utility for Intel C236.

Intel RAID Configuration Utility

The Intel RAID Configuration utility is an embedded BIOS utility for creating, managing, and deleting arrays from the controller BIOS and initializing drives.

To run the Intel RAID Configuration utility, press during system bootup to enter the BIOS Setup Utility. The main menu appears. To select an option from this or any menu, browse with the arrow keys to highlight an option and press <Enter>. In some cases, selecting an option displays another menu. To return to the previous menu at any time, press <Esc>.

Intel HostRAID Configurations

The following types of Intel HostRAID configurations are supported:

- **RAID0 (Data Striping)**—RAID0 writes data in parallel, interleaved (“striped”) sections between two hard drives. RAID0 doubles the data transfer rate (over a single hard drive) to enhance system performance. To use RAID0, two or more hard drive disks are required.
- **RAID1 (Data Mirroring)**—Use RAID1 to copy identical data from one disk drive to another. By doing so, a “mirror” of source data is created to enhance data security. To use RAID1, two or more hard drive disks are required, and the second drive must be the same size or larger than the first drive.

Configuring the AMI BIOS for SATA RAID Settings



Note Press during system bootup to enter the BIOS Setup Utility.

Follow these steps to configure the AMI BIOS for SATA RAID settings:

1. Use the arrow keys to select the **Advanced** menu from the menu bar and press <Enter> to enter the **Advanced** menu.
2. In the **Advanced** menu, scroll down to **IDE/SATA Configuration** and press <Enter> to enter the **IDE/SATA Configuration** submenu.
3. Once in the **IDE/SATA Configuration** submenu, scroll down to **Configure SATA#1 as** and press <Enter>. The Options window displays.
4. From the Options window, select **RAID** and press <Enter>.

5. Press <Esc> to return to the previous menu. Use the arrow keys to select **Exit** from the menu bar at the top and press <Enter> to enter the **Exit** submenu.
6. From the **Exit** submenu, select **Save Changes and Exit** and press <Enter> to save the changes and exit the BIOS. The system reboots.
7. After the system exits from the BIOS Setup Utility, the system automatically reboots. When the system is rebooting, press <Delete> to enter the BIOS. Select **Advanced» Intel RSTe SATA Controller** to manage RAID.

Creating a RAID0 Volume

Follow these steps to create a RAID0 volume:

1. Select **Create RAID Volume** from the main menu and press <Enter>.
2. Specify a name for the RAID0 set and press <Tab> or <Enter> to go to the next field. (To select the previous menu, press <Esc>.)
3. When **RAID Level** is highlighted, use the up and down arrow keys to select **RAID0 (Stripe)** and press <Enter>.
4. When **Disks** is highlighted, press <Enter> to select the HDD to configure for RAID.
5. Use the up and down arrow keys to highlight a drive and press the space bar to select it. A triangle appears to confirm the drive selection.
6. When **Stripe Size** is highlighted, use the up and down arrow keys to select the stripe size for your RAID0 and press <Enter>.



Note Stripe size is 4–128 KB for RAID0. For a server, use a lower stripe size; for a multimedia system, use a higher stripe size. The default stripe size is 128 KB.

7. Press <Enter> when the **Create Volume** item is highlighted. A warning message displays, indicating that all data on the selected disks will be lost.
8. At the **Are you sure you want to create this volume (Y/N)** prompt, press <Y> to create the RAID volume or <N> to return to the **Create Volume** menu.

Creating a RAID1 Volume

Follow these steps to create a RAID1 volume:

1. Select **Create RAID Volume** from the main menu and press <Enter>.
2. Specify a name for the RAID1 set and press <Tab> or <Enter> to go to the next field. (To select the previous menu, press <Esc>.)
3. When **RAID Level** is highlighted, use the up and down arrow keys to select **RAID1 (Mirror)** and press <Enter>.
4. When **Disks** is highlighted, press <Enter> to select the HDD to configure for RAID.
5. Use the up and down arrow keys to highlight a drive and press the space bar to select it. A triangle appears to confirm the drive selection.

6. When **Capacity** is highlighted, press <Enter> to specify the disk capacity to configure for RAID1.
7. Press <Enter> when **Create Volume** is highlighted. A warning message displays, indicating that all data on the selected disks will be lost.
8. At the **Are you sure you want to create this volume (Y/N)** prompt, press <Y> to create the RAID volume or <N> to return to the **Create Volume** menu.

Recovery

Use this feature to create the recovery volume by copying data from a designated master drive to a designated recovery drive.



Note A recovery drive is a backup drive to store data copied from the original (master) drive. A master drive is the original drive containing the source files to be copied to the recovery drive.

Follow these steps to create a recovery drive:

1. Select **Create RAID Volume** from the main menu and press <Enter>. The Create Volume Menu screen appears.
2. Specify a name for the recovery disk drive and press <Enter>.
3. When **RAID Level** is highlighted, use the up and down arrow keys to select **Recovery** and press <Enter>.
4. When **Select Disks** is highlighted, press <Enter> to select the HDD to create the recovery volume.
5. On the **Select Disks** screen, use the up and down arrow keys to select a drive to use as your master drive and press <Tab> to configure it as your master drive. Use the arrow keys to select your recovery drive and press the space bar to configure it. Press <Enter> to complete the disk selection.
6. When **RAID Capacity** is highlighted, enter your RAID volume capacity and press <Enter>. The default setting is the maximum capacity allowed.
7. When **Sync** is highlighted, use the up and down arrow keys to select the **Continuous** or **On Request** update policy. If you select **Continuous**, data on the master drive is copied to the recovery drive automatically as long as both drives are connected to the system. If you select **On Request**, data on the master drive is copied to the recovery drive when you request it.
8. Press <Enter> when the **Create Volume** item is highlighted. A warning message displays, indicating that all data on the selected disks will be lost.
9. At the **Are you sure you want to create this volume (Y/N)** prompt, press <Y> to create the RAID volume or <N> to return to the **Create Volume** menu without making changes.

Deleting a RAID Volume



Caution Be sure to back up your data before deleting a RAID set. You will lose all data on the drives when deleting a RAID set. You also will lose the recovery image.

Follow these steps to delete a RAID volume:

1. From the main menu, select **Delete RAID Volume** and press <Enter>.
2. Use the up and down arrow keys to select the RAID set to delete and press . A warning message displays.
3. At the **Are you sure you want to delete this volume (Y/N)** prompt, press <Y> to delete the RAID volume or <N> to return to the **Delete Volume** menu.

Resetting to Non-RAID



Caution Be careful when you reset a RAID volume HDD to a non-RAID HDD. Resetting a RAID HDD or RAID volume reformats the disk drive and deletes the internal RAID structure and contents.

Follow these steps to reset a RAID volume HDD to non-RAID:

1. From the main menu, select **Reset Disks to Non-RAID** and press <Enter>.
2. Use the up and down arrow keys to highlight the RAID set drive to reset and press the space bar to select it.
3. Press <Enter> to reset the RAID set drive. A warning message displays.
4. Press <Y> to reset the drive or <N> to return to the main menu.

Recovery Volume Options



Note A recovery drive is a backup drive to store data copied from the original (master) drive. A master drive is the original drive containing the source files to be copied to the recovery drive.

Follow these steps to select a recovery volume option:

1. From the main menu, select **Recovery Volume Options**.
2. When **Recovery Volume Options** is highlighted, press <Enter>.
3. To boot from a recovery disk only, select **Enable Only Recovery Disk** and press <Enter>.



Note If a recovery disk is available, its RAID volume recovery support is enabled, and the master disk is disabled.

4. To boot from the master disk that contains the original data sources only, select **Enable Only Master Disk** and press <Enter>.



Note If a master disk is available, its RAID volume recovery support is enabled, and the recovery disk is disabled. Any change in steps 3 or 4 stops automatic synchronization between the master and recovery drives.

5. Press <Esc> to return to the **Main** menu.

Exiting the Intel RSTe SATA Controller

Follow these steps to exit the Intel RSTe SATA Controller:

1. Press <ESC> to return to the **Advanced** menu.
2. Press <F4> to save changes and restart the system.

NI Services

NI provides global services and support as part of our commitment to your success. Take advantage of product services in addition to training and certification programs that meet your needs during each phase of the application life cycle; from planning and development through deployment and ongoing maintenance.

To get started, register your product at ni.com/myproducts.

As a registered NI product user, you are entitled to the following benefits:

- Access to applicable product services.
- Easier product management with an online account.
- Receive critical part notifications, software updates, and service expirations.

Log in to your MyNI user profile to get personalized access to your services.

Services and Resources

- **Maintenance and Hardware Services**—NI helps you identify your systems' accuracy and reliability requirements and provides warranty, sparing, and calibration services to help you maintain accuracy and minimize downtime over the life of your system. Visit ni.com/services for more information.
 - **Warranty and Repair**—All NI hardware features a one-year standard warranty that is extendable up to five years. NI offers repair services performed in a timely manner by highly trained factory technicians using only original parts at an NI service center.
 - **Calibration**—Through regular calibration, you can quantify and improve the measurement performance of an instrument. NI provides state-of-the-art calibration services. If your product supports calibration, you can obtain the calibration certificate for your product at ni.com/calibration.
- **System Integration**—If you have time constraints, limited in-house technical resources, or other project challenges, National Instruments Alliance Partner members can help. To learn more, call your local NI office or visit ni.com/alliance.
- **Training and Certification**—The NI training and certification program is the most effective way to increase application development proficiency and productivity. Visit ni.com/training for more information.
 - The Skills Guide assists you in identifying the proficiency requirements of your current application and gives you options for obtaining those skills consistent with

your time and budget constraints and personal learning preferences. Visit ni.com/skills-guide to see these custom paths.

- NI offers courses in several languages and formats including instructor-led classes at facilities worldwide, courses on-site at your facility, and online courses to serve your individual needs.
- **Technical Support**—Support at ni.com/support includes the following resources:
 - **Self-Help Technical Resources**—Visit ni.com/support for software drivers and updates, a searchable KnowledgeBase, product manuals, step-by-step troubleshooting wizards, thousands of example programs, tutorials, application notes, instrument drivers, and so on. Registered users also receive access to the NI Discussion Forums at ni.com/forums. NI Applications Engineers make sure every question submitted online receives an answer.
 - **Software Support Service Membership**—The Standard Service Program (SSP) is a renewable one-year subscription included with almost every NI software product, including NI Developer Suite. This program entitles members to direct access to NI Applications Engineers through phone and email for one-to-one technical support, as well as exclusive access to online training modules at ni.com/self-paced-training. NI also offers flexible extended contract options that guarantee your SSP benefits are available without interruption for as long as you need them. Visit ni.com/ssp for more information.
- **Declaration of Conformity (DoC)**—A DoC is our claim of compliance with the Council of the European Communities using the manufacturer’s declaration of conformity. This system affords the user protection for electromagnetic compatibility (EMC) and product safety. You can obtain the DoC for your product by visiting ni.com/certification.

For information about other technical support options in your area, visit ni.com/services, or contact your local office at ni.com/contact. You also can visit the Worldwide Offices section of ni.com/niglobal to access the branch office websites, which provide up-to-date contact information, support phone numbers, email addresses, and current events.

Glossary

Symbol	Prefix	Value
p	pico	10^{-12}
n	nano	10^{-9}
μ	micro	10^{-6}
m	milli	10^{-3}
k	kilo	10^3
M	mega	10^6
G	giga	10^9
T	tera	10^{12}

Symbols

° Degrees

W Ohms

% Percent

A

A Amperes

A/D Analog-to-digital. Most often used as *A/D converter*.

AC Alternating Current

ACPI Advanced Configuration and Power Management Interface

ANSI American National Standards Institute

API Application Programming Interface—A standardized set of subroutines or functions along with the parameters that a program can call.

APIC Advanced Programmable Interrupt Controller

Glossary

ASCII	American Standard Code for Information Exchange
ASIC	Application-Specific Integrated Circuit
ATA	The specification formulated in the 1980s that defines the IDE drive interface.
B	
B	Bytes
BIOS	Basic Input/Output System—BIOS functions are the fundamental level of any PC or compatible computer. BIOS functions embody the basic operations needed for successful use of the computer's hardware resources.
C	
C	Celsius
CAS	Column Address Strobe
CMOS	Complementary Metal Oxide Semiconductor—A process used in making chips.
COM	Communications port
CPU	Central Processing Unit
CSA	Carrier Serving Area
D	
D/A	Digital-to-analog—Most often used as an abbreviation for a D/A converter (also known as DAC).
DC	Direct Current
DDR	Double Data Rate
DIMM	Dual In-line Memory Module

DMA	Direct Memory Access—A method by which data is transferred between devices and internal memory without intervention of the central processing unit.
DMI	Desktop Management Interface
DRAM	Dynamic RAM (Random Access Memory)—Storage that the computer must refresh at frequent intervals.

E

ECC	Error-Correcting Code
EDO RAM	Extended Data Output RAM—A type of random access memory (RAM) chip that improves the time to read from memory on faster microprocessors such as the Intel Pentium.
EEPROM	Electrically Erasable Programmable Read Only Memory
EMC	Electromagnetic Compatibility
EMI	Electromagnetic Interference
EPP	Enhanced Parallel Port

F

FCC	Federal Communications Commission
-----	-----------------------------------

G

GB	Gigabytes of memory
GPB	General Purpose Interface Bus (IEEE 488)

H

HDD	Hard Disk Drive
Hz	Hertz; cycles per second

I

I/O	Input/output—The techniques, media, and devices used to achieve communication between machines and users.
IDE	Integrated Drive Electronics—Hard disk and built-in controller.
IEEE	Institute of Electrical and Electronics Engineers
IRQ*	Interrupt signal
ISA	Industry Standard Architecture—The original PC bus architecture, specifically the 16-bit AT bus.

K

KB	Kilobytes of memory
----	---------------------

L

LAN	Local Area Network—Communications network that serves users within a confined geographical area. It is made up of servers, workstations, a network operating system, and a communications link.
LCD	Liquid Crystal Display—A display technology using polarizing filters and liquid crystal cells.
LED	Light-emitting diode

M

MAX	Measurement & Automation Explorer
MB	Megabytes of memory
MPS	Multiprocessor Specification
MTBF	Mean Time Between Failure
MTTR	Mean Time to Repair
MXI	Multisystem eXtension Interface

N

NI-DAQ	The National Instruments software for data acquisition instruments.
NI-VISA	The National Instruments implementation of the VISA standard—An interface-independent software that provides a unified programming interface for VXI, GPIB, and serial instruments.

P

PCI	Peripheral Component Interconnect. The PCI bus is a high-performance 32-bit or 64-bit bus with multiplexed address and data lines.
PEF	Platform Event Filter
PIO	Programmed Input/Output
POSC	Power On Self Configuration
POST	Power On Self Test
PXI	PCI eXtensions for Instrumentation—An open implementation of CompactPCI that adds electrical features that meet the high-performance requirements of instrumentation applications by providing triggering, local buses, and system clock capabilities. PXI also offers two-way interoperability with CompactPCI products.

R

RAM	Random Access Memory—The computer's primary workspace.
RAS	Row Address Strobe
RMS	Root Mean Squared
RTC	Real Time Clock—An electronic circuit that maintains the time of day and also can provide timing signals for timesharing operations.

S

SATA	Serial-ATA. <i>See also</i> ATA .
SCSI	Small Computer System Interface
SDRAM	A form of dynamic RAM memory that is about 20% faster than EDO RAM. SDRAM interleaves two or more internal memory arrays so that while one array is being accessed, the next one is being prepared for access. SDRAM-II is a faster version of SDRAM technology.
SO-DIMM	Small Outline Dual In-line Memory Module
SPD	Serial Presence Detect EEPROM
SRAM	Static RAM—A memory chip that requires power to hold its content. It does not require refresh circuitry as a dynamic RAM chip, but it does take up more space and uses more power.

U

UDMA	Ultra Direct Memory Access. <i>See also</i> DMA .
USB	Universal Serial Bus

V

V	Volts
VGA	Video Graphics Array—The minimum video display standard for all PCs.
VISA	Virtual Instrument Software Architecture—A single interface library for controlling GPIB, VXI, RS232, and other types of instruments. VISA has been standardized by the <i>VXI Plug&Play</i> Systems Alliance.
VME	Versa Module Eurocard
VXI	VME eXtensions for Instrumentation

W

W

Watts

WDT

Watchdog Timer

Index

A

AC power cables (table), 1-2
AMI BIOS for SATA RAID settings,
configuring, C-1

B

BIOS
checking settings, 4-1
flashing new BIOS, 4-3
boot options, configuring controller, 4-2

C

cables, power (table), 1-2
CE compliance specifications, A-4
common configuration questions, 4-1
boot options, 4-2
chassis configuration, 4-2
general questions, 4-1
upgrade information, 4-3
cooling, air cooling of RMC-8356, 2-2

D

DDR DIMMs
from National Instruments (note), 1-6
installing, B-22
removing, B-23
drivers, obtaining latest, 4-3

E

electromagnetic compatibility, A-4
environmental management
specifications, A-4

G

ground, connecting, 2-3

H

hard disk drives
upgrading and replacing, B-24
hard drive part numbers, B-26

I

IDE controller, using SCSI hard drive in
addition, 4-1
installation, 2-2
configuration and operation
connecting safety ground, 2-3
site considerations, 2-2
testing power up, 2-3
unpacking the RMC-8356, 1-1
installing RMC-8356, 2-1
Intel HostRAID configurations, C-1
Intel Matrix Storage Manager utility,
exiting, C-5
Intel RAID Configuration utility, C-1
configuring AMI BIOS for SATA RAID
settings, C-1
creating recovery volume, C-3
creating volumes
RAID0, C-2
RAID1, C-2
deleting a RAID volume, C-4
exiting Intel Matrix Storage Manager
utility, C-5
Intel HostRAID configurations, C-1
recovery volume options, C-4
resetting a RAID HDD, C-4
resetting to non-RAID, C-4
Intel SATA RAID utility for Intel C236, C-1

K

key features, 1-2
kit contents, 1-1

L

LabVIEW, 1-6
LabWindows/CVI, 1-6
LEDs, front panel, 4-1

M

maintenance of RMC-8356
cleaning, exterior, 2-35
Measurement Studio, 1-6

memory

- installation, B-21
- support, B-21
- system memory allocation and availability, B-21
- upgrading, 1-6, B-20
 - installing DDR modules, B-22
 - removing DDR modules, B-23

modular instruments, 1-6

N

National Instruments software, 1-6

NI-DAQmx, 1-6

NI-VISA, 1-7

Non-RAID, resetting to, C-4

O

optional equipment, 1-6

- memory upgrades, 1-6

OS reinstallation and recovery, 2-36

overview, 1-2

P

power cables (table), 1-2

power supply, connecting to, 2-3

power up, testing, 2-3

`pxisys.ini` file, 4-2

R

rack mount kit dimensions (figure), A-5

rack mounting, 2-36

RAID HDD, resetting, C-4

RAID volume, deleting, C-4

RAID0 volume, creating, C-2

RAID1 volume, creating, C-2

RAM

- DDR DIMMs from National Instruments (note), 1-6
- upgrading, 4-3

recovery volume

- creating, C-3
- options, C-4

replacing hard disk drives, B-24

RMC-8356

- boot options, 4-2
- chassis configuration, 4-2
- chassis cooling considerations, 2-2
- common configuration questions, 4-1
- configuration, hardware, B-1
- description, 1-4
- front panel LEDs, 4-1
- hard drive part numbers, B-26
- hardware configuration, B-1
- installation, 2-1, 2-2
- key features, 1-2
- memory upgrades, 1-6
- overview, 1-2
- power source, connecting to, 2-3
- rack mounting, 2-36
- safety and caution notices, 2-1
- safety ground, connecting, 2-3
- software, 1-6
- troubleshooting, 5-1
- upgrade information, 4-3
- upgrade/optional equipment, 1-6
- upgrading and replacing hard disk drives, B-24
- upgrading memory, B-20
- upgrading RAM, 4-3
- using with PXI chassis, 4-2

S

safety and caution notices, 2-1

safety ground, connecting, 2-3

safety, specifications, A-3

SATA RAID utility, C-1

software

- See also* drivers
- LabVIEW, 1-6
- LabWindows/CVI, 1-6
- Measurement Studio, 1-6
- National Instruments software, 1-6
- NI-DAQmx, 1-6
- NI-VISA, 1-7

specifications

- CE compliance, A-4
- electrical, AC input, A-1
- electromagnetic compatibility, A-4

- environmental management, A-4
- rack mount kit dimensions (figure), A-5
- safety, A-3

T

- testing power up, 2-3
- troubleshooting
 - controller does not boot, 5-1
 - damaged module, 5-2
 - video display, 5-1

U

- unpacking the RMC-8356, 1-1
- upgrade equipment, 1-6
- upgrading hard disk drives, B-24
- upgrading memory, B-20
 - installing DDR modules, B-22
 - removing DDR modules, B-23